

Guarantee

We grant a **three-year guarantee** from the date of purchase.

This product was manufactured using the latest production techniques and has undergone thorough quality control inspection. We guarantee that the product is in perfect condition.

We will remedy all defects in workmanship or materials within the guarantee period. In order for the guarantee to be granted, all warranty claims must be accompanied by proof of purchase from Tchibo or from an authorised Tchibo distribution partner.

If, contrary to our expectations, a defect is found, please contact our customer care service at the following e-mail address:

service@tchibo.de

Our customer consultants will be pleased to advise you on further procedure.

Damage due to improper use, as well as worn parts and consumables, are not covered by the guarantee.

Please have the product number at hand in case of any queries.

This guarantee does not restrict statutory warranty rights.

Product number: EN 304 244



Food Processor

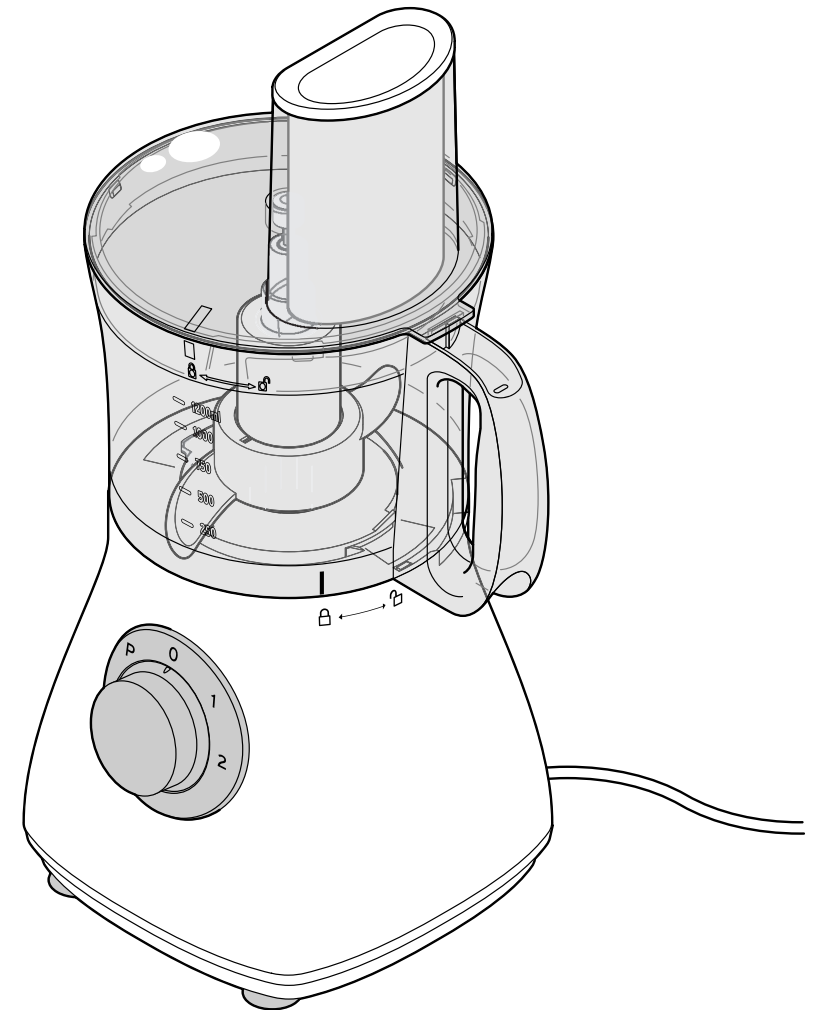

en Instructions for use and guarantee

Tchibo GmbH D-22290 Hamburg · 74120AS2X11V · 2013-11

Dear Customer

Your new food processor is ideal for mixing dough, whipping cream and beating egg whites, as well as shredding and chopping fruits and vegetables.

The accessories include a chopping blade, a mixing blade, a julienne cutter, blades for chips and slices as well as a whisking disc for cream or egg whites.

The food processor has two speed settings and a pulse function. Suction pads on the base ensure it stands firmly and securely while you work.

Your Tchibo Team

Contents

3 About these instructions for use	13 Which attachment is suitable for which purpose?
3 Safety warnings	13 Whisking disk for cream and egg whites
6 Technical specifications	13 Slicing blade
7 At a glance (features)	13 Blade for cutting strips
8 Prior to first-time use	14 Blade for julienne slices
9 Assembling the food processor	15 Mixing blade
9 1. Setting up the appliance	15 Chopping blade
9 2. Attaching the drive spindle and bowl	16 Operation
10 3. Fitting the attachment holder	18 Cleaning
10 4. Selecting and fitting the attachments	19 Problems / solutions
12 5. Attaching the lid	19 Disposal
12 6. Inserting the food pusher	20 Guarantee

Problems / solutions

Not working.	<ul style="list-style-type: none">• Is the appliance plugged in?• Is the bowl positioned correctly?• Is the lid positioned correctly? <p>The bowl and lid must be securely in place - see section "Assembling the food processor".</p>
When cutting slices, strips or julienne slices, the blade disk moves very slowly.	<ul style="list-style-type: none">• Is the feed tube blocked?• Is the food you have inserted unsuitable for use? Pieces that are too large, too hard or too soft are not suitable for use in the slicer. Do not process ice cubes, deep-frozen foods or any other hard food items.• Are you pushing down too hard on the food pusher?
The appliance switches off while in operation.	<ul style="list-style-type: none">• Has the appliance overheated? The safety feature to avoid overheating was activated. Let the appliance cool down to room temperature before switching it back on.

Disposal

The product and its packaging have been manufactured from valuable materials that can be recycled. Recycling reduces the amount of refuse and helps to preserve the environment.

Dispose of the **packaging** at a recycling point that sorts materials by type. Make use of the local facilities provided for collecting paper, cardboard and lightweight packaging.



Appliances marked with this symbol must not be disposed of along with normal household refuse!

You are legally obliged to dispose of old appliances separately from household refuse. You can obtain information on collection points where you can dispose of old appliances free of charge from your local authorities.

Cleaning



DANGER - risk of fatal electric shock

- Remove the mains plug from the wall socket before cleaning the appliance.
- The motor unit must not be exposed to moisture. Also protect it against drips and splashes of water.



WARNING - risk of injury

- Some of the attachments are extremely sharp. Use caution when cleaning!

CAUTION - material damage

- Do not use caustic, aggressive or abrasive products for cleaning.

Whenever possible, clean all accessories immediately after use to prevent food from drying on them.

1. Remove the mains plug from the wall socket.
2. Remove the lid, attachment, attachment holder and bowl from the motor unit.
3. Clean the motor unit with a slightly moistened cloth.
4. Rinse the other parts in warm water and a little washing-up liquid.

To avoid accidentally cutting yourself, make sure that the water used for cleaning is clear enough for you to see the blades.

All parts (excluding the motor unit) are dishwasher safe. Arrange them in the top basket and wash at a maximum temperature of +50°C.

5. Rinse all parts with clear water afterwards.
6. Thoroughly dry all parts. Leave to air dry if possible before reassembling the appliance.



Processing strongly coloured foods such as carrots can discolour the plastic parts. In most cases, discolouration of this type can be easily removed with a small amount of cooking oil. Discolouration will neither harm the plastic nor affect taste.

About these instructions for use

This product is equipped with safety features. Nevertheless, read the safety warnings carefully and only use the product as described in these instructions to avoid accidental injury or damage.

Keep this manual for future reference. If you pass this product on to someone else, remember give them these instructions.

Symbols used in these instructions:



This symbol warns you of the danger of injury.



This symbol warns you of the danger of injury caused by electricity.

The term **DANGER** warns of potential severe injury and danger to life.

The term **WARNING** warns of injury and severe material damage.

The term **CAUTION** warns of minor injury or damage.



This indicates additional information.

Safety warnings



Intended use

- The food processor is intended for processing standard household quantities of food and is not suitable for commercial purposes.
- Only use the accessories for the purposes stated in these instructions.
- The appliance is not suitable for processing very hard food items such as coffee beans, nuts, deep-frozen vegetables, ice cubes or meat with bones.

DANGER to children and people with reduced capabilities of operating appliances

- Children must not be allowed to play with the appliance. The appliance must not be operated by children. Keep the packaging material and mains cord out of reach of children.
- This appliance may be used by people with reduced physical, sensory or mental capabilities or lack of sufficient experience and/or knowledge, provided they are supervised or have been trained in the safe use of the appliance and understand the potential dangers.

- Put the appliance in a place where children cannot reach it.
- Keep the packaging material out of the reach of children.
There is a risk of suffocation!

DANGER - risk of electric shock due to moisture

- The motor unit, mains cord and mains plug must not be immersed in water or come into contact with other liquids as there is otherwise a risk of electric shock. Never touch the appliance switch or mains plug while your hands are wet.
- Do not use the appliance outdoors. Never expose the appliance to rain or moisture. Do not store it in rooms exposed to moisture such as a cellar or garage.

DANGER due to electricity

- To avoid hazards, do not operate the appliance if the motor unit, mains cord, bowl or lid show any signs of damage. Nor should you use any accessories that are damaged.
- Only connect the appliance to a properly installed, easily accessible wall socket with the same mains voltage rating as that indicated in the appliance's technical specifications.
- The mains cord must not be kinked or squeezed. Keep the mains cord away from hot surfaces and sharp edges. Route the mains cord so that the appliance cannot be pulled down by it.

- Disconnect the mains plug from the wall socket...
...after use,
...before attaching or removing accessories,
...before cleaning the appliance or
...if malfunctions occur during use.
Always pull on the plug, never on the cord.
- Do not make any modifications to the appliance and do not attempt to replace the mains cord yourself. Only have repairs to the appliance or its mains cord carried out by a specialist workshop, or contact the customer care service. Improper repair can result in considerable risk of injury to the user.

WARNING - risk of injury

- Always turn the rotary switch to **0** after use. The appliance is only properly switched off when the rotary switch is set to the **0** position.
- Before removing the lid or bowl, always switch the appliance off first and disconnect the mains plug from the wall socket.
- Never leave the appliance unattended while it is connected to the mains.
- Do not use the appliance if the blades are wedged or rotate with difficulty.
- Never poke any kitchen utensils such as spoons, knives or similar objects into the rotating blades or other moving parts.

- Place the ingredients into the bowl. Do not fill higher than the **1200 ml** mark.
- Position the lid on the bowl as described in the section "Assembling the food processor".
Ensure that the bowl is correctly fitted onto the motor unit and the lid is correctly fitted on the bowl. The appliance cannot be switched on if either of the two parts are fitted incorrectly.
- Plug the mains plug into an easily accessible wall socket.

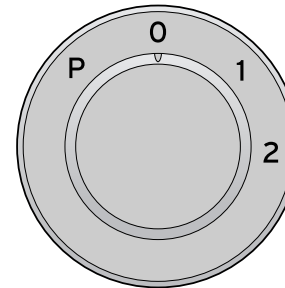

- To switch on the appliance, turn the rotary switch to speed
1 (slow),
2 (fast) or
P (pulse).

Continue processing until the desired consistency is achieved, but...

- ... on **P** only in 2 to 3-second increments,
- ... on **1** or **2** not longer than about 30 seconds.

Then let the appliance cool down for approx. 2 minutes.



The speed setting **2** is suitable for mixing dough or whisking liquids. Use the pulse setting **P**, for example, if you want to chop food finely with the blade attachment without pureeing it.

- If required, slowly pour any liquid or free-flowing ingredients through the feed tube into the bowl while the processor is running.
Always guide any remaining food in the feed tube using the food pusher - never push it down with your hands!

CAUTION - material damage

- To avoid damaging the food processor, do not switch the appliance on and off by turning the lid. Always use the rotary switch instead.

- To turn the processor off, turn the rotary switch to **0**.
Wait until the parts have stopped moving and disconnect the plug from the wall socket before taking off the lid.
- Take the blade attachment out first and then empty the bowl using a wooden or plastic spatula.

Preparing food

- Where applicable, wash and pat food dry (e.g. meat, bread, vegetables) and dice more or less evenly (about 1.5 cm in size).
- Remove the leaves of herbs from their stalks and process as dry as possible.
- Remove sinew and skin from meat.

Preparing dough

- Take ingredients such as butter straight from the refrigerator and cut into cubes about 1.5 cm in size.
- First place the dry ingredients (flour, salt, sugar, etc.) into the bowl. Then add the cubes of butter.
- Run the processor on speed setting **2** but do not exceed the maximum time of 30 seconds.
- Pour the measured quantity of liquid (water, milk, etc.) through the feed tube while the motor is running.
- Switch the appliance off once the dough has formed a ball.
- Dough becomes leathery if it is processed for too long.
- Take the dough out of the bowl and knead briefly by hand.

Operation



WARNING - risk of injury

- Always guide the food through the feed tube using the food pusher. Do not put your fingers into the feed tube!
- Always wait until the attachment has stopped moving. Remove the mains plug from the wall socket before taking off the lid.
- Always remove the blade attachment before emptying the bowl.

1. Place the appliance on a clean, dry and even surface. The suction pads will keep it firmly in place and prevent it from slipping.
2. Select the appropriate attachment.
3. Put together the appliance as described in the section "Assembling the food processor", but do not put the lid on yet.

- Never put your hand into the bowl while the appliance is in use. Do not touch any parts of the appliance when they are still in motion.
- If mixture sticks to the sides of the bowl, do not attempt to scrape it off while the appliance is operating. Switch the appliance off first and disconnect the mains plug from the wall socket. Always use a wooden or plastic spatula.
- Never guide food into the feed tube with your hands. Always use the food pusher instead.
- Insert the required attachment before placing the ingredients in the bowl.
- The attachments will continue turning for a short time after switching the appliance off. Before removing the lid or bowl, always wait for the attachment to come to a stop. Remove the mains plug from the wall socket.
- The blades are very sharp. Be particularly careful when you insert and clean them. Always take hold of the blades by their plastic part. When washing the blades by hand, the water should be clear enough to see them well.
- When not in use, always store the chopping blade in its protective cover.
- For your safety, the appliance has been designed to work only when the bowl is positioned correctly and the lid locked in place. Should the appliance operate even when the bowl and/or lid are not properly in place, stop using it and contact the customer care service.

CAUTION - material damage

- The appliance is designed for short-time operation. Switch it off after a maximum of 30 seconds. Let the appliance cool for approx. 2 minutes before switching it on again.
- Do not switch on the appliance while the bowl is empty. The motor could overheat and become damaged.
- Do not overfill the bowl. Be sure to observe the maximum level mark.
- Place the appliance on a level, non-slip and non-sensitive work surface.
- Maintain sufficient distance from sources of heat such as hotplates or ovens. Never place the appliance onto hot surfaces.
- Do not carry the appliance by the bowl.
- If preparing chopped food: do not add any liquids to bind the chopped food.
- Cut firm ingredients into small pieces before putting them into the bowl to prevent the blades from getting stuck.
- Do not use the appliance to process ingredients that are too hard (e.g. ice cubes or bones).
- Do not process spices or coarse sugar. These may damage the plastic.
- Prevent almond essence or other essences from coming into direct contact with the plastic. These may cause discolouration.

- Processing strongly coloured foods such as carrots can discolour the plastic parts. These discolourations can be mostly removed if cleaned immediately and affect neither the quality of the plastic nor the taste of food being prepared.
- Do not use any caustic or abrasive cleaning products, or hard brushes, etc. for cleaning.
- Only use the original attachments.

- Some types of varnish, synthetic substances or furniture polish may react adversely to the material of the suction pads, soften them and leave unwanted traces on the work surface. Therefore, place a non-slip mat under the appliance if necessary.

Technical specifications

Model:	304 244
Mains voltage:	220-240 V ~ 50 Hz
Protection class:	II <input type="checkbox"/>
Power:	500 watts
Short-time operation:	max. 30 seconds / 2-minute pause
Bowl capacity:	max. 1200 ml
Ambient temperature:	+10 to +40°C
Made exclusively for:	Tchibo GmbH, Überseering 18, 22297 Hamburg, Germany

In the course of product improvement, we reserve the right to make technical and optical modifications to the product.



Mixing blade

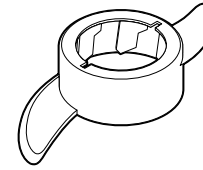

For preparing

- shortcrust pastry using up to 400 g flour
- yeast dough using up to 400 g flour

i If you want ingredients such as raisins to stay whole, you must work them in later by hand.

Chopping blade

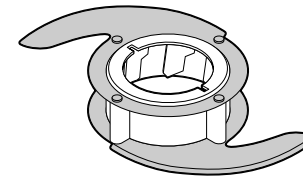

For chopping

- up to 500 g raw meat
- onions, herbs, vegetables, cooked meat, nuts, etc.

For blending food such as cooked vegetables.

i Cooked potatoes cannot be mashed with the blade attachment.

Tips on chopping and mixing

- The food processor does its work in seconds, not minutes. To preserve the texture of food, do not run the processor for too long.
- Use speed setting **2** for mixing or kneading. With some ingredients, you will obtain a smoother result if you use the pulse setting **P**.
- If you would like to cut up biscuits (such as sponge fingers), break them into pieces and pass them through the feed tube while the motor is running.
- Do not add any liquids to bind chopped food.
- To scrape off food that is stuck to the sides of the bowl, wait for the blade to stop moving, unplug the appliance before opening the lid, and then scrape the food that is stuck to the middle of the bowl using a wooden or plastic spatula - never your fingers!

Blade for julienne slices



For cutting fine strips of vegetables, potatoes and similar, especially for use raw in salads, as a garnish, etc. or for quick deep-frying.

Tips on cutting and slicing

- Do not cut or slice food for longer than 30 seconds at a time. Then let the appliance cool down for approx. 2 minutes.
- Use food that is as fresh as possible.
- Use speed setting **2** for cutting and slicing.

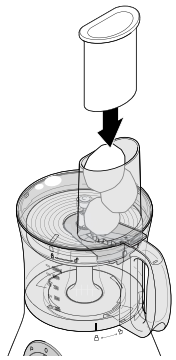

Place the food into the feed tube. Fill up the feed tube as far as possible, so that the food remains in the given position and is evenly pushed down by the food pusher.

Guide the food through the feed tube as evenly as possible with the food pusher.

- For longer strips, place the food item into the feed tube horizontally (e.g. for julienne slices). For shorter strips, place them in vertically.
- Empty the bowl from time to time if the sliced food mounts up inside the bowl. Always wait until the attachment has stopped moving and disconnect the plug from the wall socket before opening the lid and reaching into the bowl.
- Small quantities of unsliced food will always be left on the disc and in the bowl.

At a glance (contents)

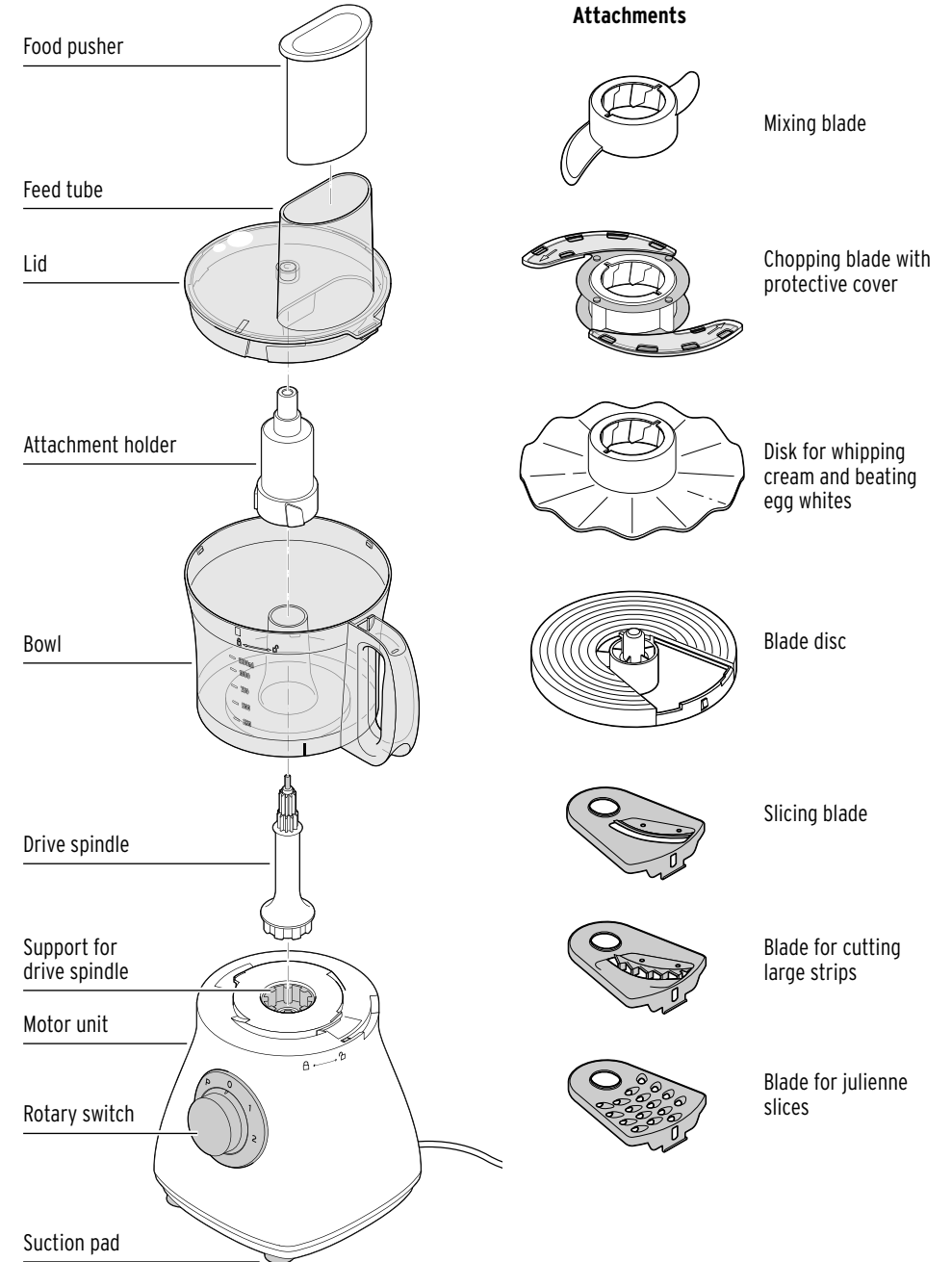

First-time use



DANGER to children - danger to life due to suffocation/choking

- Keep the packaging material away from children. Dispose of it immediately.



WARNING - risk of injury

- Some of the attachments are extremely sharp. Be careful when unpacking and cleaning!

1. Take all parts out of the packaging and remove all packing material.
2. Clean all accessories apart from the motor unit thoroughly with warm water and a little washing-up liquid before using the appliance for the first time. The motor unit can be wiped with a slightly moistened cloth.
3. Rinse the attachment parts in clear water and then dry them well.



All parts (excluding the motor unit) are dishwasher safe. Arrange them in the top basket and wash at a maximum temperature of +50°C.

Which attachment is suitable for which purpose?



WARNING - risk of injury

- Be careful when handling the blades! The cutting edges are very sharp. Always take hold of the blades by their plastic part.

Whisking disk for cream and egg whites

For whipping cream or beating egg whites.

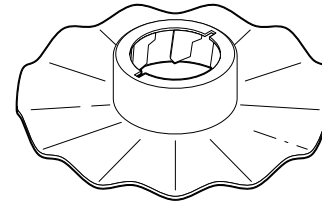

Tips for preparing cream and egg whites

- Clean the bowl and disc thoroughly before beating egg whites. Make sure that there are no traces of butter, yolk or other fats sticking to the parts or in the egg white, otherwise it will not stiffen.
- Process cream when it is as cold as possible; eggs should preferably be at room temperature.
- Use speed setting **2** for whipping cream or beating egg whites.
- If they are required, drizzle ingredients such as sugar slowly through the feed tube while the appliance is running.
- Switch off the appliance, wait until the parts have stopped moving, disconnect the plug from the wall socket, take off the lid and remove the disc. Empty out the whisked ingredients using a wooden or plastic spatula.

Slicing blade

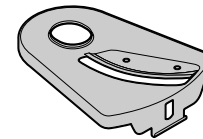

For slicing carrots, potatoes, cabbage, cucumbers, courgettes, beetroot, onions, etc.

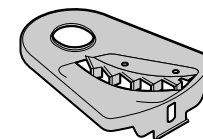

Blade for cutting strips

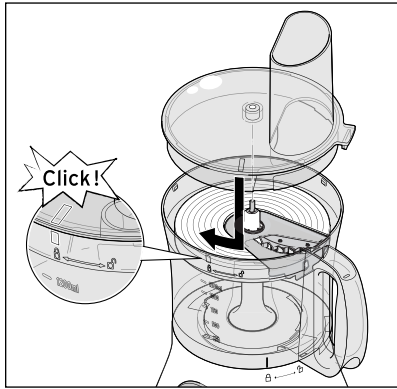

For cutting vegetables into strips or sticks, e.g. carrots, potatoes, cabbage, cucumbers, courgettes, beetroot, onions, etc.

5. Attaching the lid



1. Place the lid on the bowl so that the mark on the lid is positioned over the  symbol on the bowl.
2. Then turn the lid clockwise until the mark on the lid is positioned over the  symbol on the bowl.

 If the lid is not correctly positioned, the appliance cannot be switched on.

6. Inserting the food pusher

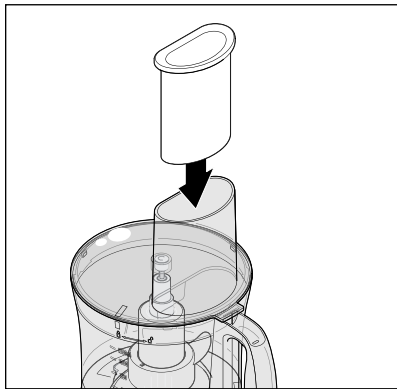

- ▷ Insert the food pusher into the feed tube.

 **WARNING** - risk of injury

- Always guide the food through the feed tube using the food pusher. Do not put your fingers into the feed tube!

The food processor is now ready for use.

Assembling the food processor



WARNING - risk of injury

- Make sure that the appliance is not connected to the mains supply and the rotary switch is on 0.

1. Setting up the appliance

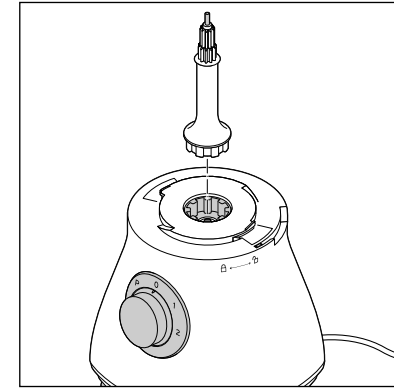

- ▷ Unwind the cord completely.
- ▷ Stand the appliance on a stable, dry, level and non-sensitive work surface. The suction pads beneath the motor unit adhere to all smooth surfaces. The surface must be clean and flat. The suction pads will not adhere to textured surfaces.

2. Attaching the drive spindle and bowl

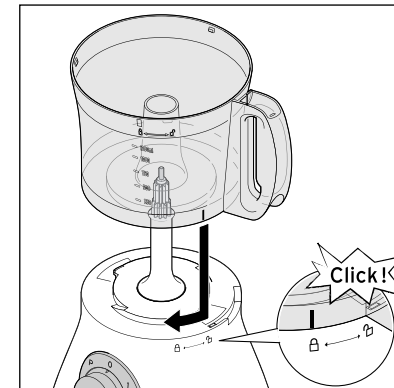

1. Fit the drive spindle in place in the appliance.



2. Place the bowl on the drive spindle so that the mark on the bowl is positioned over the  symbol on the motor unit.
3. Then turn the bowl clockwise until the mark on the bowl is positioned over the  symbol.

 If you do not position the bowl correctly, the appliance cannot be switched on.

3. Fitting the attachment holder

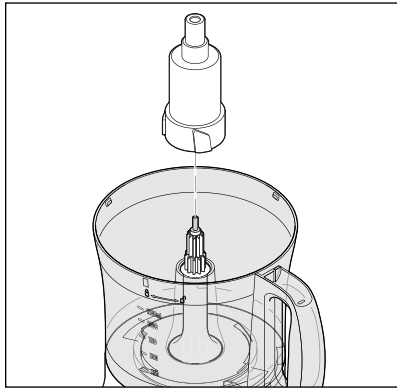

- ▶ Push the attachment holder onto the drive spindle.

4. Selecting and fitting the attachments



WARNING - risk of injury

- Some of the attachments are extremely sharp. Be careful when handling the blades!

Attaching the mixing or chopping blade

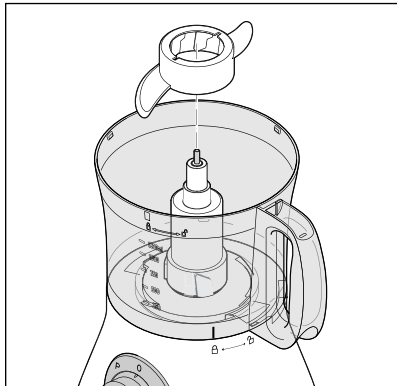

- ▶ Place the mixing or chopping blade onto the attachment holder as illustrated. The two gaps in the rim should be pointing upwards.

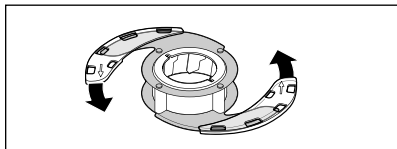

- Remove the protective cover from the chopping blade before use.

Attaching the whisking disk

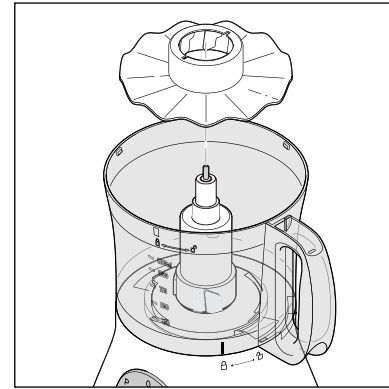

- ▶ Place the disk onto the attachment holder as illustrated.

Attaching the slicing, cutting or julienne blades

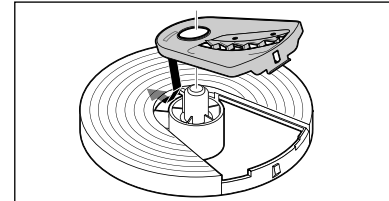

1. Insert the required blade diagonally into the blade disk as illustrated.

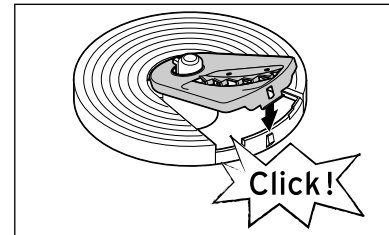

2. Then push the blade downwards until it clicks into place.

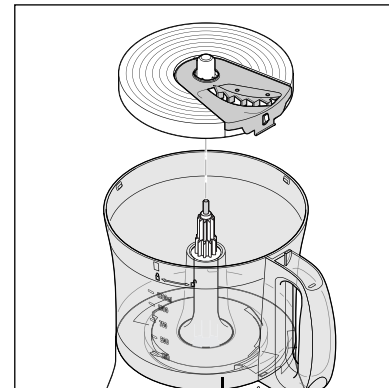

3. Place the disk onto the attachment holder as illustrated.