

Important safeguards

ENGLISH

- This appliance is designed for home air conditioning and must not be used for other purposes.
- It is dangerous to modify or alter the characteristics of the appliance in any way.
- The appliance must be installed in conformity with legislation in force in the country concerned.
- If the appliance requires repair, contact a Service Centre authorised by the manufacturer only. Repairs carried out by unauthorised personnel may be dangerous.
- If the power cable is damaged, it must be replaced by a qualified professional authorised by the manufacturer only.
- This air conditioning unit must be used by adults only. Never allow children to play with the appliance.
- The appliance must be connected to an efficient earth system. Have your electrical circuit checked by a qualified electrician.
- Do not use extension cables.
- Before cleaning or maintenance operations, always unplug the appliance from the mains socket.
- Do not move the appliance by pulling the power cable.
- Do not install the appliance in rooms containing gas, oil or sulphur. Do not install near sources of heat.
- Do not rest heavy or hot objects on top of the appliance.
- Clean the anti-microbial filters at least once a week.
- Avoid using heating appliances near the air conditioning unit.
- Always transport the appliance upright or resting on one side.
Before moving the appliance, empty the internal circuit completely of water. Press the **MODE (B)** and **FAN (T)** buttons simultaneously for a number of seconds without removing the tank (8) and then empty the tank (8).
After moving the appliance, wait at least 1 hour before starting it.
- Use the appliance as described in this instruction manual only. As with any electrical appliance, while the instructions aim to cover as many eventualities as possible caution and common sense should be used when operating and installing this air conditioning unit.
- At the end of its working life, take the appliance to a special collection centre.
- The materials used for packaging can be recycled. You are therefore recommended to dispose of them in special differentiated waste collection containers.
- When putting the appliance away, do not cover with plastic bags.
- The refrigerant gases R290 and R407c conform to EC regulations on the environment. Avoid perforating the refrigerant circuit of the appliance.
- Keep the appliance at least 50 cm away from flammable substances (alcohol etc) or pressurised containers (eg aerosol cans).

For environmentally-friendly models only (T90ECO, T100ECO)

- If the appliance is used in rooms without adequate ventilation, take the necessary precautions to avoid possible leaks of refrigerant gas stagnating in the atmosphere, creating a fire risk.
- This appliance must be used and kept in rooms with a volume of more than 21m³.
- If an appliance containing flammable refrigerant is used in an unventilated room, make sure the room is suitable and that there is no danger of gas leaks reaching a concentration which could cause fire or explosion in the presence of other heat sources (electrical heating appliances, heaters or similar).

DESCRIPTION

- | | |
|--|--|
| 1 air outlet grille (motorised in model T100 ECO only) | 11 flange cap |
| 2 control panel | 12 air exhaust hose |
| 3 castors | 13 window outlet |
| 4 handles | 14 suckers |
| 5 air exhaust hose housing | 15 castor locks |
| 6 condenser air intake grille | 16 continuous drain hose with coupling |
| 7 evaporator air intake grille | 17 remote control unit (model T100 ECO only) |
| 8 condensate tank | 18 3M air purifying filter accessory (model T100 ECO only) |
| 9 continuous condensate drain connection | |
| 10 power cable | |

What are the Pinguino and SuperPinguino?

During the summer, you feel comfortable at a temperature of between 24 and 27° C with a relative humidity of about 50%.

An air conditioning unit removes excess moisture and heat from the room where it is located. Compared with installed models, portable air conditioning units have the advantage that they can be moved from one room to another in the home or be transported from one building to another.

Hot air from the room is passed through a coil cooled by refrigerant gas. Excess heat and moisture are removed before the air is re-emitted into the room.

In single unit models (Pinguino), a small part of this air is used to cool the refrigerant gas and then, when hot and damp, is discharged outside.

In models with case (SuperPinguino), the circuit is cooled using air from outside.

All Pinguino and SuperPinguino models can also be used in fan-only mode.

The Pinguino ECO is a latest generation environmentally-friendly air conditioning unit. The Pinguino ECO does not, in fact, contain gases (CFC/HCFC) dangerous to the ozone layer or with a marked greenhouse effect (HFC). As well as reducing energy consumption, the high efficiency of the appliance also minimises impact on the greenhouse effect.

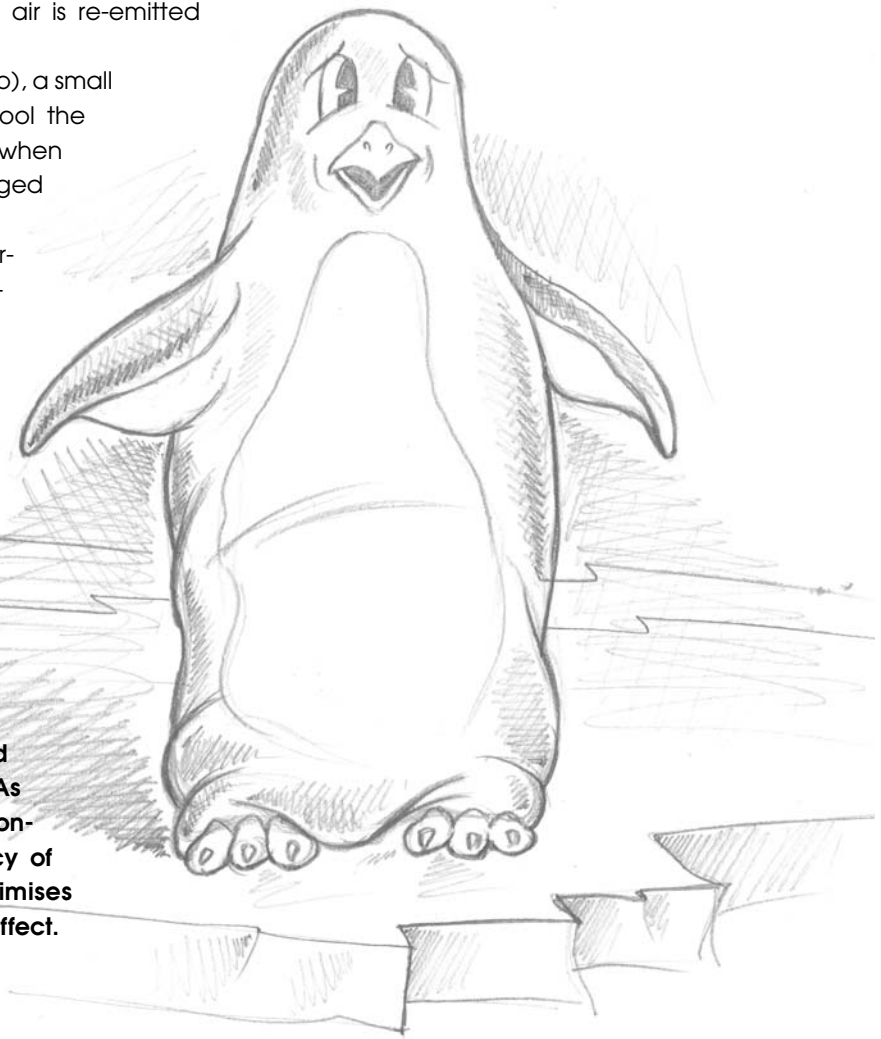

Preparing for use

ELECTRICAL CONNECTIONS

Before plugging the appliance into the mains socket, check that:

- the mains power supply corresponds to the value indicated on the rating plate on the back of the appliance;
- the mains socket and electrical circuit are adequate for the appliance;
- the mains socket matches the plug. If this is not the case, have the plug replaced;
- the mains socket is adequately earthed. **Failure to follow these important safety instructions absolves the manufacturer of all liability.**

The power cable must be replaced by a qualified professional only.

The instructions below will enable you to prepare your air conditioning unit for operation as efficiently as possible.

Before use, make sure the air intake and outlet grilles are unobstructed.

AIR-CONDITIONING WITHOUT INSTALLATION

Just a few simple steps and your comfort is ensured with Pinguino:

- Fit the air exhaust hose **12** in the housing **5** at the back of the appliance. Insert it as shown in figure **A**.

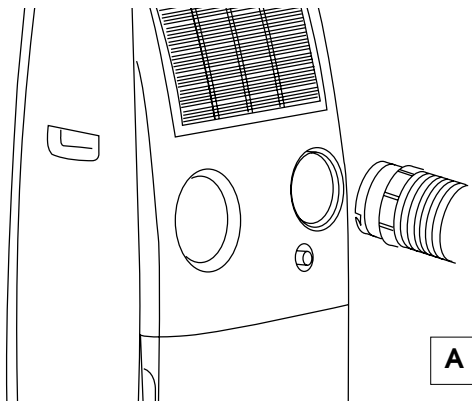

- Fit the window outlet **12** to the end of the hose **13**.
- Place the air conditioning unit near a window or French window.
- Make sure the air exhaust hose is unobstructed.
- Open the window or French window slightly and position the outlet **13** as shown in figure **B**.

Keep air hoses as short and free of curves as possible to avoid constrictions.

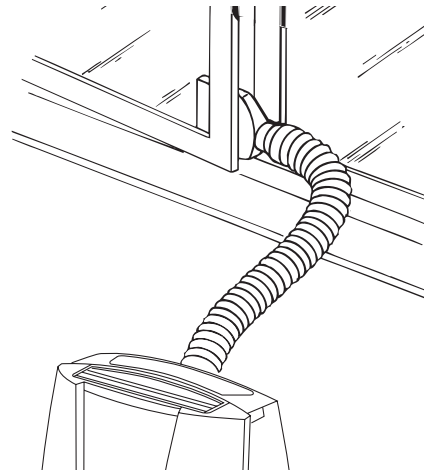

- If you have a double window, use the suckers **14** provided to hold the two parts of the window together (fig. **C**).

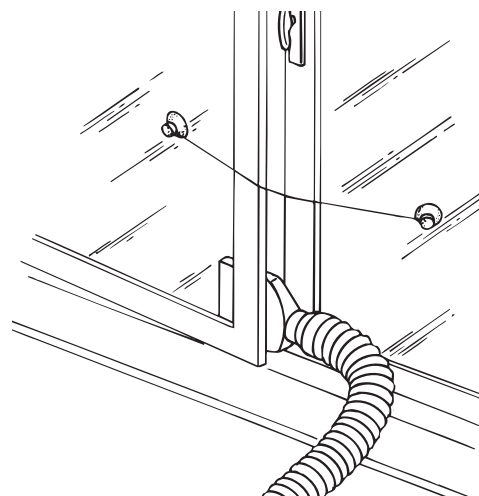

Preparing for use

AIR-CONDITIONING WITH INSTALLATION

If required, the Pinguino can also be installed semi-permanently.

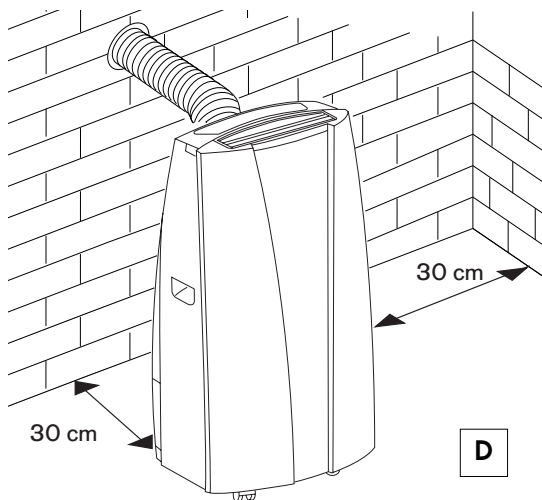

- Fit the flange accessory provided in the hole
- Fit the hose **12** in the housing at the back of the appliance (fig. **A** page 19).
- Fit the end of the hose **12** to the flange **11** as shown in fig. **E**.

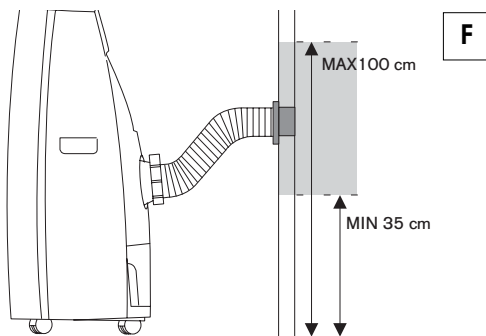

Proceed as follows:

- Drill a hole in an outside wall or through a window pane. Respect the height and dimensions of the hole given in figure **D**.

When the hose **12** is not fitted, the hole can be closed with the flange cap **11**.

NOTE:

When installing the air conditioning unit semi-permanently, you should leave a door slightly open (as little as 1 cm) to guarantee correct ventilation.

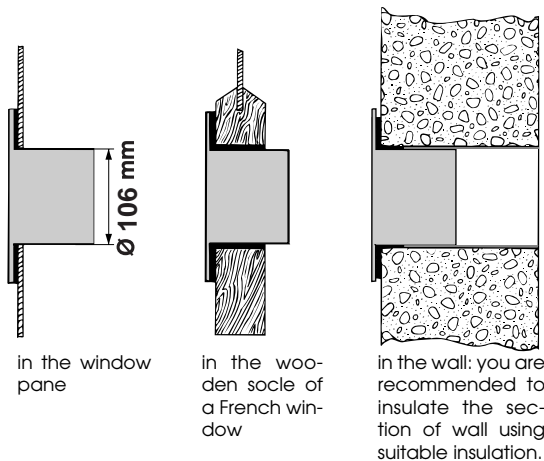

E

Keep the air hoses as short and free of curves as possible to avoid constrictions.

DEHUMIDIFYING

Place the appliance in the room without fitting the hose. The dehumidified air will thus be released directly into the atmosphere. Cold air will be discharged from the front grille and hot air from the back grille (fig. **G**), thus guaranteeing efficient dehumidifying.

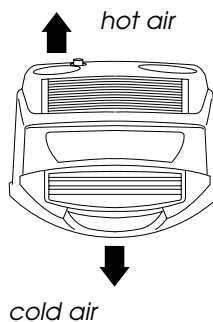

G

Description of the control panel

THE CONTROL PANEL

A ON/OFF button

B Mode selection button

Conditioning, BOOST (superconditioning), dehumidifying, fan.

C Air conditioning mode indicator light

D BOOST (superconditioning) mode indicator light

E Dehumidifying mode indicator light

F Fan mode indicator light (air purifying in model T100ECO)

G Increase temperature/humidity/ programmed operating time button

H Timer in operation indicator light

I Display displays the temperature/humidity values set and the programmed operating time

L Timer button

M Temperature display

N Humidity display

O Reduce temperature/humidity/programmed operating time button

P/Q/R/S Fan speed and AUTO mode indicator lights

T Fan speed selection button

U "SWING" button to move grille flaps (model T100ECO only)

NB: The "SWING" button (U) moves the grille flaps to distribute the cool air uniformly in the room. When the button (U) is pressed and the flaps have begun moving alternately forwards and backwards, pressing the button again will lock the flaps in their current position. Pressing the button again will restart the flaps moving forwards and backwards. When the appliance is turned off, they will close irrespective of their position.

MODELS WITH REMOTE CONTROL UNIT (model T100ECO only)

Operation

- Pressing the **ON/OFF** button (⏻) turns the appliance on or off.
- Pressing the **FAN** button selects the required fan speed. Each time the **FAN** button is pressed, the speed of the fan rotates through the available options (Max, Min, Silent, Auto). On the control panel, the LED corresponding to the selected speed lights up.
- The **SET** buttons (+) and (-) increase or reduce temperature or humidity. The temperature or humidity set is displayed on the control panel.

Each time the button is pressed, the appliance confirms the selection with a beep and the light on the remote control unit comes on.

NB: The remote control unit can be used for the following functions only: to turn the appliance on or off, vary fan speed and set temperature or humidity depending on the operating mode selected on the control panel. (see pages 22-23)

Replacing the batteries

- Remove the cover on the back of the remote control unit;
- replace the flat batteries with two AAA 1.5 V batteries, making sure they are in the correct position (see instructions inside the battery compartment);
- Replace the cover.

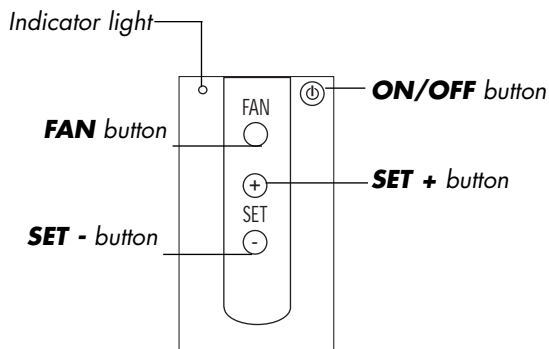

Operation

TURNING THE APPLIANCE ON

Plug into the mains.

Two lines appear on the display indicating that the appliance is in standby.

Press the **ON/OFF** button (**A**) (when turned on, the air conditioning unit starts operating in the same mode as when it was turned off).

Press the **MODE** (**B**) button until the indicator light corresponding to the required mode lights up:



Indicator light **C**  : Air-conditioning mode

Indicator light **D**  : BOOST mode (superconditioning)

Indicator light **E**  : Dehumidifying mode

Indicator light **F**  : FAN MODE (air purifying in model T100 eco only) (in model T100eco, when the selection has been made, the flaps will open at a pre-set angle. When the air conditioning unit is turned off, the flaps will reclose).

AIR-CONDITIONING MODE

Ideal for hot humid weather when you need to cool and dehumidify the room.

After selecting the air-conditioning mode, the indicator light (**M**) comes on. To set operation of the appliance correctly, press the "+" (**G**) or "-" (**O**) buttons until the required temperature is displayed.

The most suitable temperature for the room during the summer varies from 24 to 27°C. You are recommended, however, not to set a temperature much below the external temperature.

Then select the fan speed by pressing the **"FAN"** button (**T**) until the indicator light corresponding to the required fan speed lights up:

MAX (S): the air conditioning unit operates at maximum to reach the required temperature as rapidly as possible.

MIN (R): reduces noise levels but still maintains a good level of comfort

SILENT (Q): for silent operation

AUTO (P): the appliance automatically selects the most suitable fan speed in relation to the temperature set on the digital display.



BOOST MODE (superconditioning)

This is set in the same way as the "AIR-CONDITIONING" mode, but with a boost, useful when you want to make a very hot room comfortable as rapidly as possible.

Operation

DEHUMIDIFYING MODE

Ideal for reducing the humidity in a room without lowering or raising the temperature (spring or autumn, damp rooms, rainy spells, etc).

Place the appliance in the room without fitting the air exhaust hose [12].

After selecting the dehumidifying mode, the indicator light (N) comes on. Press the "+" (G) or "-" (O) buttons until the required humidity is displayed.

At the same time, the auto fan indicator light (P) comes on as the appliance automatically selects the most appropriate speed.

Water is removed from the air and collected in the tank [8] at the back of the air conditioning unit.

When full, the appliance shuts down and "Fl" (full tank) appears on the display. The tank must be extracted and emptied (fig. H).

When the tank has been emptied, the appliance starts up again.

NB: remove the air exhaust hose [17] if it gets in the way.

The accessory [16] enables the condensate produced to be eliminated without requiring the tank to be emptied periodically.

The accessory is fitted into the rapid coupling [9] as shown in fig. I.

NB: in order for continuous drain to function, make sure the accessory is connected correctly to the coupling. To release, press the coupling flange.

FAN MODE (AIR PURIFYING T100ECO ONLY)

Adjust fan speed by pressing the "FAN" button (T) as described for the air-conditioning mode.

Remember that the higher the speed, the more air is filtered. If you select "Silent" speed, less air is filtered but the appliance is also less noisy.

In this mode, "AUTO" cannot be selected. The fan speed selected will be displayed.

"3M Filtrete" air purifying filter (T100 eco only)

Ideal for dusty or polluted environments. The T100ECO model circulates and purifies the air with the help of 3M Filtrete™ electrostatic dust filters.

In addition to removing dust, the air purifying filter also captures the smallest impurities (down to 0.003 mm), such as cigarette smoke.

To use the air purifying filter:

- A) Remove the intake grille [7].
- B) Remove the filter from the packaging.
- C) Use the two plastic edges to attach the filter to the hooks on the dust filter inside the intake grille.
- D) Replace the grille on the appliance.

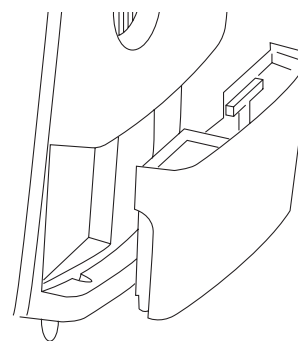

H

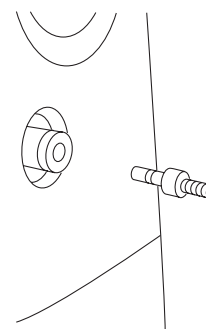

I

ENGLISH

Operation

SETTING THE TIMER

The timer can be used to delay appliance start up or shut down. This avoids wasting electricity by optimising operating periods. To set, press the "+" (G) or "-" (O) button to increase or decrease by an hour at a time. When the buttons are held down for more than two seconds, the time runs rapidly up to a maximum of 24 hours.

How to programme delayed start up

- Plug the appliance into a mains socket and press the **ON/OFF** button (A), then select the required mode and operation (temperature, fan speed, etc).
- Press the **ON/OFF** button (A) again to place the appliance in standby mode.
- Press the timer button (L). The two centre segments flash on the display.
- Use the "+" (G) or "-" (O) buttons to set the number of hours delay before the appliance comes on.
- The indicator light (H) flashes until the appliance starts up.
- You can set the appliance to come on with a delay of up to 24 hours.

How to programme delayed shut down

- Delayed shut down can be programmed in any operating mode (air conditioning / superconditioning / dehumidifying / fan / air purifying).
- Press the timer button (L). The two centre segments flash on the display.
- Use the "+" (G) or "-" (O) button to set the number of hours delay before the appliance goes off.
- The indicator light (H) flashes until the appliance shuts down. At the set time, the air conditioning unit shuts down and remains in standby.

Operation

SELF DIAGNOSIS

The appliance has a self diagnosis system to identify a number of malfunctions.

ENGLISH

IF ... IS DISPLAYED	...WHAT SHOULD YOU DO?
Lt LOW TEMPERATURE (frost prevention)	When the appliance is operating in air conditioning, BOOST (super-conditioning) or dehumidifying mode, this device prevents the formation of ice. The appliance start up again automatically when the defrosting process is completed.
PF PROBE FAILURE (sensor damaged)	If this is displayed, contact your service centre.
Ft FULL TANK	Empty the tank at the back of the appliance and replace correctly. The continuous drain hose is not connected correctly or is obstructed and the air conditioning unit is draining into the tank.
F1 (FAILURE 1) PUMP MALFUNCTION	If this is displayed, contact your service centre.

Tips

To get the best from your air conditioning unit, follow these recommendations:

- close the windows and doors in the room to be air conditioned. The only exception is when the appliance is installed through a hole in the wall.

In this case, you are recommended to leave a slight draught through a door or window to guarantee correct ventilation.

- Never use the appliance in very damp rooms (laundries for example).
- Never use the appliance outdoors.

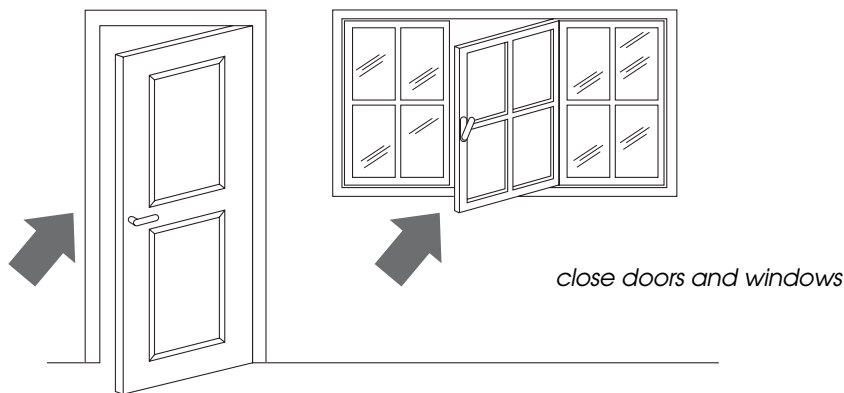

- Protect the room from direct exposure to the sun by partially closing curtains and/or blinds to make the appliance much more economical to run;
- Never rest objects of any kind on the air conditioning unit;
- Never obstruct the air intake **7** or outlet **1** grilles;
- Make sure there are no heat sources in the room.

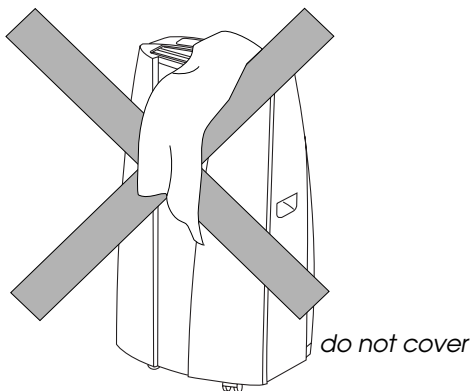
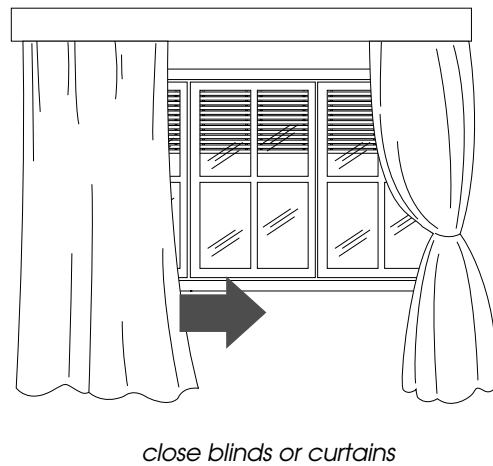

- Make sure the air conditioning unit is on a **level floor**. If necessary, place the two castor locks **15** under the front wheels **3**.

Cleaning

Before cleaning or maintenance, turn the appliance off by pressing the ON/OFF button (A) and always unplug from the mains socket.

CLEANING THE CABINET

You should clean the appliance with a slightly damp cloth then dry with a dry cloth. For safety reasons, never wash the air conditioning unit with water.

Precautions

Never use petrol, alcohol or solvents to clean the appliance. Never spray insecticide liquids or similar.

CLEANING THE AIR FILTERS

To keep your air conditioning unit working efficiently, you should:

1. Clean the dust filter every week of operation.
2. Replace the 3M air purifying filter (model T100ECO only) at the end of each season or when exhausted (see the instructions near the filter housing on the appliance). The filters are housed in the intake grille. To clean the filters, proceed as follows:

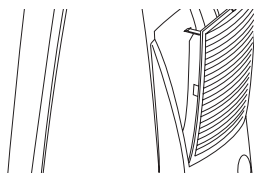

L

1. Remove the intake grille by rotating outwards (fig.L).
2. Remove the first 3M air purifying filter (white) (model T100ECO only).
3. Remove the dust filter by detaching it from the grille.

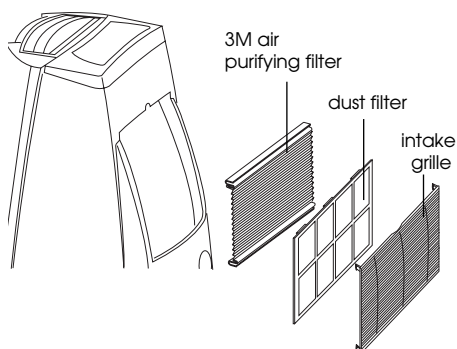

M

Use a vacuum cleaner to remove the dust collected on the anti-microbial filter. If it is very dirty, immerse in warm water and rinse a number of times. The water should never be hotter than 40°C.

After washing, leave the filter to dry.

To replace, put the filters back in the intake grille then attach the intake grille to the appliance.

Never try and clean the 3M filter as this could reduce its filtering capacity.

START OF SEASON CHECKS

Make sure the power cable and plug are undamaged and the earth system is efficient. Follow the installation instructions precisely.

END OF SEASON OPERATIONS

Place the appliance in standby.

To empty the internal circuit completely of water, press the **MODE (B)** and **FAN (T)** buttons simultaneously for a number of seconds without removing the tank **8**.

The water in the internal circuit will drain into the tank **8** or through the continuous drain hose **9** if connected.

Make sure the other end of the hose leads to a drain.

Disconnect the continuous drain hose.

Clean the filters and dry thoroughly before putting back.

Troubleshooting

PROBLEM	CAUSE	REMEDY
The air conditioning unit is off	<ul style="list-style-type: none"> • no electricity • it is not plugged into the mains • the safety device has tripped • the safety float has tripped 	<ul style="list-style-type: none"> • wait • plug into the mains • contact your service centre • empty the tank
The air conditioning unit works for a short time only	<ul style="list-style-type: none"> • the exhaust hose has a constriction • the exhaust hose is blocked • there are bends in the exhaust hose 	<ul style="list-style-type: none"> • position the exhaust hose correctly • check there are no obstacles obstructing air discharge • eliminate the bends
The air conditioning unit works, but does not cool the room	<ul style="list-style-type: none"> • window open • there are heat sources in the room (burner, lamp, etc) • the exhaust hose is detached • air filters clogged • the air conditioning unit is not powerful enough for the conditions or size of the room 	<ul style="list-style-type: none"> • close the window • eliminate the heat source • connect the exhaust hose • clean or replace the filters
Particular odour in the room	<ul style="list-style-type: none"> • air filters clogged 	<ul style="list-style-type: none"> • clean or replace the filters
The air conditioning unit does not operate for about three minutes after turning it on	<ul style="list-style-type: none"> • the safety device has tripped 	<ul style="list-style-type: none"> • wait for three minutes
LT/ FT/PF/FI. appears on the display The full indicator light is on	<ul style="list-style-type: none"> • See "self-diagnosis" section 	

Guarantee/technical specification

GUARANTEE AND TECHNICAL ASSISTANCE

The conditions of the guarantee and technical assistance are given on the certificate supplied with your appliance.

LIMIT CONDITIONS	
Room temperature	21 ÷ 35°C

TECHNICAL SPECIFICATION

Power supply voltage	see rating plate
Max. absorbed power during air conditioning	"
Max. absorbed power during dehumidifying	"
Refrigerant	"
Cooling capacity	"

Dimensions internal unit:

• width	495 mm
• height	940 mm
• depth	410 mm
• weight	34 kg

ENGLISH

Transport, filling, cleaning, recovery and disposal of refrigerant should be performed by a technical service centre appointed by the manufacturer only.
The appliance should be disposed of by a specialist centre appointed by the manufacturer only.