

**ELECTRIC FRYER  
FRITEUSE ÉLECTRIQUE  
ELEKTRISCHE FRITTEUSE  
FRIGGITRICE ELETTRICA  
ELEKTRISCHE FRITEUSE  
FREIDORA ELÉCTRICA  
FRITADEIRA ELÉCTRICA  
ΗΛΕΚΤΡΙΚΗ ΦΡΙΤΕΖΑ  
ELEKTRISK FRITUREGRYDE  
ELEKTRISK FRITYRGRYTE  
ELEKTRISK FRITÖS  
SÄHKÖRASVAKEITIN  
ЭЛЕКТРИЧЕСКАЯ  
ФРИТЮРНИЦА  
ELEKTROMOS OLAJSÜTŐ  
ELEKTRICKÝ FRITOVACÍ HRNEC  
FRYTKOWNICA ELEKTRYCZNA**

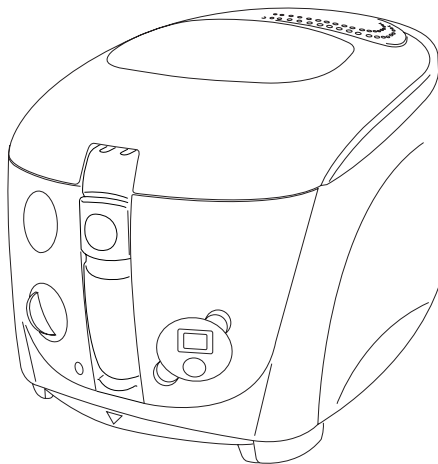

**INSTRUCTIONS FOR USE  
INSTRUCTIONS D'UTILISATION  
GEBRAUCHSANWEISUNG  
ISTRUZIONI PER L'USO  
GEBRUIKSAANWIJZINGEN  
INSTRUCCIONES PARA EL USO  
MANUAL DE INSTRUÇÕES  
ΟΔΗΓΙΕΣ ΧΡΗΣΗΣ  
BRUGSANVISNINGER  
BRUKSANVISNING  
BRUKSANVISNING  
ΚΑΥΤΟΟΗJEET  
ИНСТРУКЦИИ ПО ЭКСПЛУАТАЦИИ  
HASZNÁLATI ÚTASÍTÁS  
NÁVOD K POUŽITÍ  
INSTRUKCJA OBSŁUGI**



## ELECTRICAL REQUIREMENTS (ONLY FOR UK)

**Before using this appliance ensure that the voltage indicated on the product corresponds with the main voltage in your home, if you are in any doubt about your supply contact your local electricity company.**

The flexible mains lead is supplied connected to a B.S. 1363 fused plug having a fuse of 13 amp capacity.

Should this plug not fit the socket outlets in your home, it should be cut off and replaced with a suitable plug, following the procedure outlined below.

**Note:** Such a plug cannot be used for any other appliance and should therefore be properly disposed of and not left where children might find it and plug it into a supply socket - with the obvious consequent danger.

**N.B.** We recommend the use of good quality plugs and wall sockets that can be switched off when the machine is not in use.

**IMPORTANT:** the wires in the mains lead fitted to this appliance are coloured in accordance with the following code:

GREEN AND YELLOW	EARTH
BLUE	NEUTRAL
BROWN	LIVE

As the colours of the wires in the mains lead of this appliance may not correspond with the coloured markings identifying the terminals in your plug, proceed as follows:

The wire which is coloured green and yellow must be connected to the terminal in the plug which is marked with the letter E or by the earth symbol  $\perp$  or coloured green or green and yellow.

The wire which is coloured blue must be connected to the terminal which is marked with the letter N or coloured black.

The wire which is coloured brown must be connected to the terminal which is marked with the letter L or coloured red.

When wiring the plug, ensure that all strands of wire are securely retained in each terminal. Do not forget to tighten the mains lead clamp on the plug. If your electricity supply point has only two pin socket outlets, or if you are in doubt, consult a qualified electrician.

Should the mains lead ever require replacement, it is essential that this operation be carried out by a qualified electrician and should only be replaced with a flexible cord of the same size.

After replacement of a fuse in the plug, the fuse cover must be refitted. If the fuse cover is lost, the plug must not be used until a replacement cover is obtained. The colour of the correct replacement fuse cover is that of the coloured insert in the base of the fuse recess or elsewhere on the plug. Always state this colour when ordering a replacement fuse cover.

Only 13amp replacement fuses which are ASTA approved to B.S. 1362 should be fitted.

This appliance conforms to the Norms EN 55014 regarding the suppression of radio interference.

### WARNING - THIS APPLIANCE MUST BE EARTHED

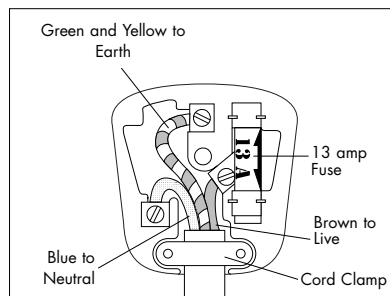

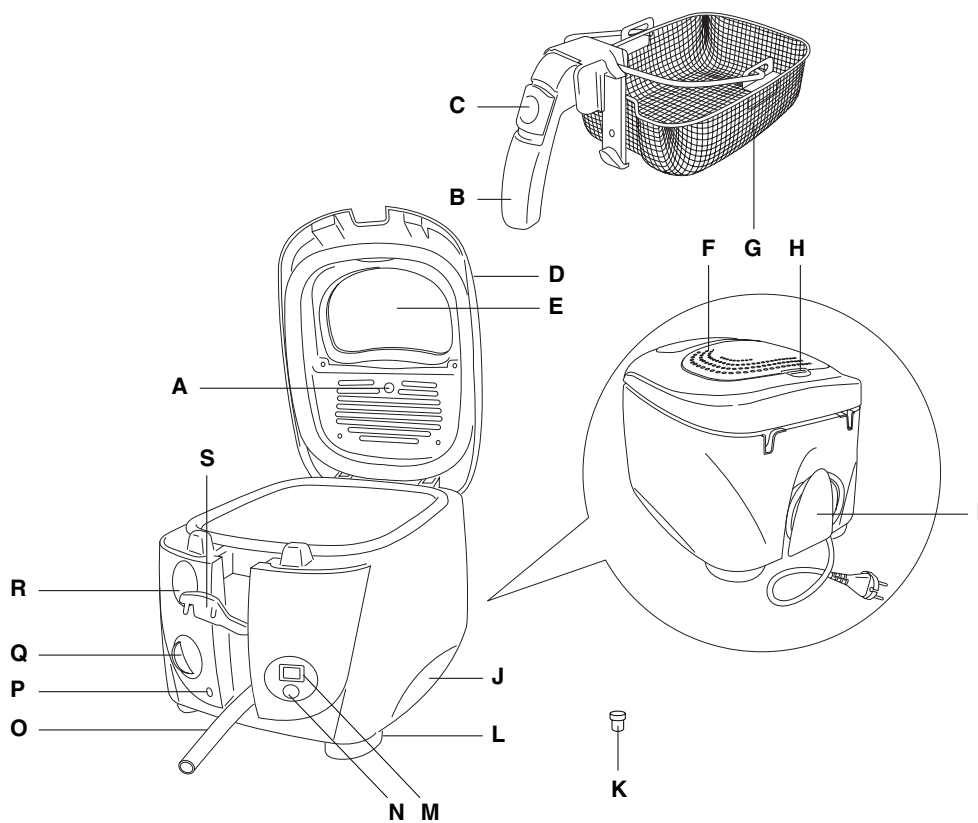

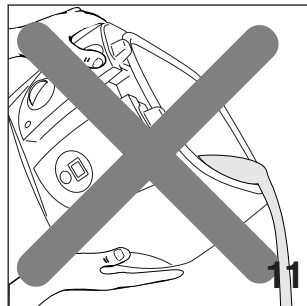
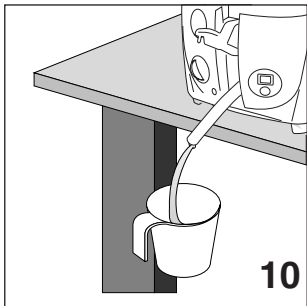
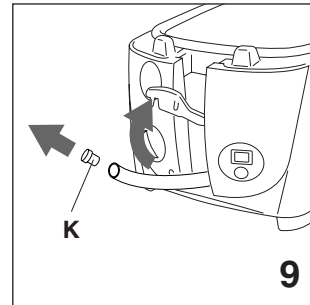
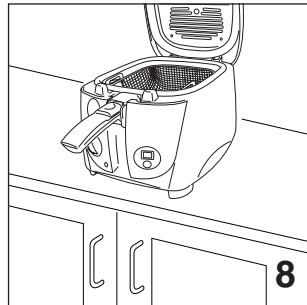
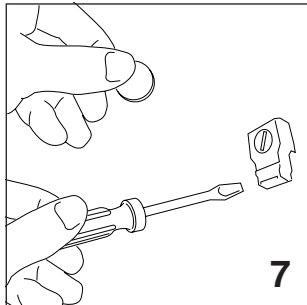
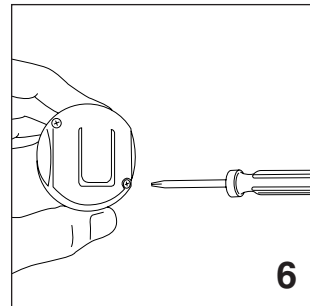
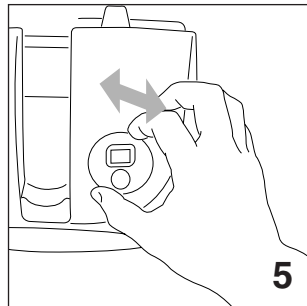
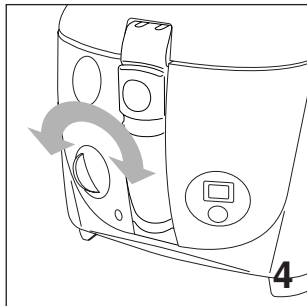
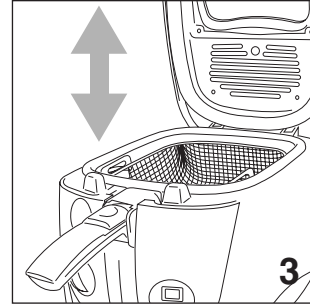
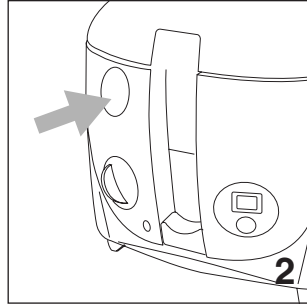
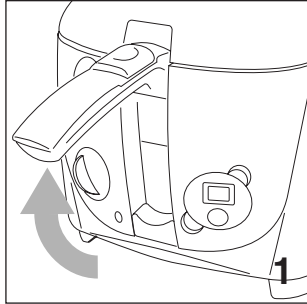

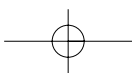
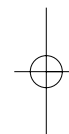
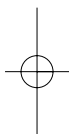
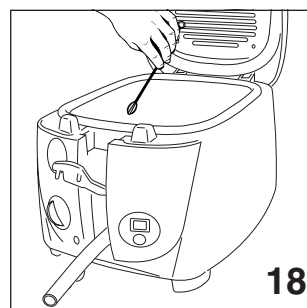
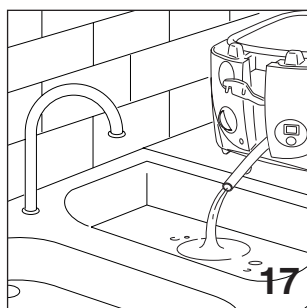
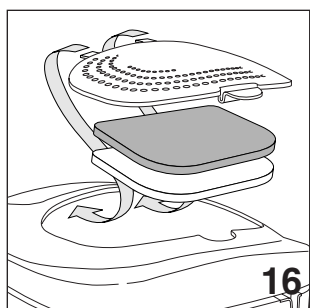
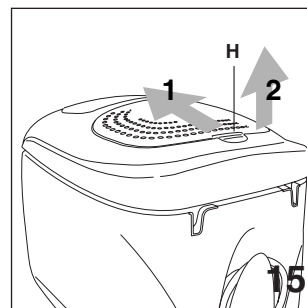
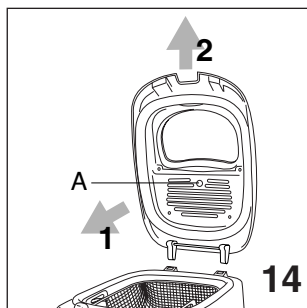
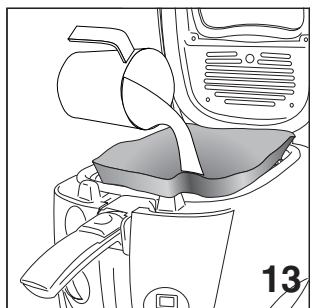
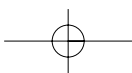

**GB****I M P O R T A N T**

- As with any electrical appliance, whilst the instructions aim to cover as many eventualities as possible, caution and common sense should be applied when operating your fryer, particularly in the vicinity of young children.
- Before use check that the voltage power supply corresponds to the one shown on the appliance data plate.
- Only connect the appliance to electrical sockets which have a minimum load of 10A and which are properly earthed. (If the socket and the plug on the appliance should prove incompatible, get a professionally qualified technician to replace the socket with a more suitable one).
- Do not place the appliance near heat sources.
- Do not immerse the deep fryer in water. By getting inside the water would cause electric shocks.
- The appliance is hot when it is in use. **DO NOT LEAVE IT WITHIN THE REACH OF CHILDREN.**
- Hot oil can cause serious burns. Do not move the deep fryer when the oil is hot.
- Never touch the viewing window when frying as it becomes very hot.
- **To move the appliance, use the special lifting handles "J". (Never lift by the basket handle).**
- **The deep fryer must only be switched on after it has been filled with oil or fat. If it is heated while empty, a thermal safety device comes into operation which stops it from working. In this case it is necessary to contact our nearest authorised service centre to replace the device.**
- If the deep fryer leaks oil, contact the technical service centre or staff authorised by the Company.
- Wash the following carefully with hot water and washing up liquid before using the deep fryer for the first time: the fryer bowl, the basket and the lid (remove filters). Also flush through the oil drain tube with hot water and washing up liquid, rinse with hot water, then dry carefully when this has been completed.
- The materials and objects likely to come into contact with foodstuffs conform to EEC Directive.
- The drainage pipe must always be closed and placed in its compartment while the appliance is in use.
- Using the appliance for the first time may result in minimal smoke. This is normal and disappears in few minutes. The room must be ventilated.
- Children or infirm persons should not be allowed to use this product unsupervised.
- Children should not be allowed to play with this appliance.
- Do not allow the cord to hang over the edge of the worksurface where it may be grabbed by children or become entangled with the user. Do not use with an extension cord.
- If it is necessary to replace the power supply cable, be sure to use a H05VVF cable consisting of three 1 mm<sup>2</sup> wires. The replacement cable must be in compliance with current safety legislation and must have the same diameter as the original cable.

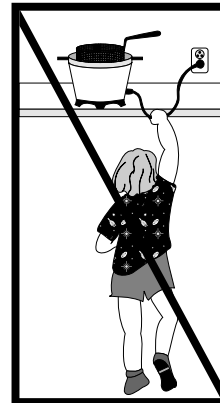

## DESCRIPTION OF THE APPLIANCE

- |  |  |
|--|--|
| A. Hole for filter control             | K. Drainage pipe plug                        |
| B. Basket handle                       | L. Foot                                      |
| C. Handle slide                        | M. Minute timer display (not for all models) |
| D. Lid                                 | N. Minute timer button (not for all models)  |
| E. Viewing window (not for all models) | O. Oil drainage pipe                         |
| F. Filter cover                        | P. Signal lamp                               |
| G. Basket                              | Q. Thermostat and on/off knob                |
| H. Filter cover hook                   | R. Lid open button                           |
| I. Cable holder compartment            | S. Door for drain pipe storage               |
| J. Handle for lifting the appliance    |  |

## OPERATING INSTRUCTIONS

- Before use, check that the mains power supply corresponds to the voltage supply indicated on the appliance.
- Before use, wash the bowl the lid (remove filters) and the basket using hot water then carefully dry the bowl.
- Never switch on the fryer before adding oil or fat. If the fryer is operated without oil or fat, a thermostatically operated safety device interrupts the operation of the appliance. In this case, it is necessary to contact one of our authorized service centres before re-using the appliance.

### FILLING WITH OIL OR FAT

- Raise the basket to the highest position by pulling the special "B" handle upwards (fig.1).  
**The lid should ALWAYS be closed when the basket is raised and lowered.**
- Open lid "D" by pressing button "R" (fig.2).
- Remove the basket by pulling it upwards (fig.3).
- Pour into the container 2.2 litres of oil (or 2 kg. of fat).

### WARNING

**The level must always be between the maximum and minimum levels indicated.**

**Never use the deep fryer when the oil is below the "min" level as it could cause the thermal safety device to come into operation; to replace it you need to contact one of our service centres.**

Best results are obtained by using a good quality oil. Avoid mixing different types of oil. If you use lumps of solid fat, cut them into small pieces so that the deep fryer does not heat up in the first few minutes without a covering of fat. The temperature must be set to 150°C until the fat has melted completely. The required temperature can then be set.

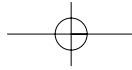

## STARTING TO FRY

1. Put the food which is to be fried into the basket, without ever overfilling it (max. 1.25 kg. of fresh potatoes).  
If cooking food from frozen, make sure very little ice is included (see frying frozen food).
2. Put the basket into the fryer bowl in a raised position (fig. 3) and close the lid by pressing lightly down upon it until the hooks click. Always close the lid before lowering the basket in order to avoid hot oil from splashing out.
3. Set thermostat knob "Q" to the required temperature (fig.4). When the temperature set has been reached, signal lamp "P" will switch off.
4. Never touch the viewing window when frying as it becomes very hot.
5. As soon as the signal lamp switches off, immerse the basket in the oil, lowering the handle slowly after sliding the handle's slider back "C".
  - It is completely normal for a considerable amount of very hot steam to rise out of filter cover "F" immediately after this.
  - At the start of cooking, immediately after the food has been immersed in the oil, the internal wall of viewing window "E" (where present) will steam up, before progressively clearing.
  - It is normal for drops of condensation to form around the basket handle while the appliance is working.

## IN THE MODELS FITTED WITH THE ELECTRONIC MINUTE TIMER

Set the cooking time by pressing key "N"; display "M" will show the minutes set.

The figures will begin flashing immediately afterwards, signifying that the cooking time has started. The last minute will be visualised in seconds.

In the event of error, the new cooking time can be set by keeping the key pressed down for more than 2 seconds. The display will reset itself, then repeat the process again.

The minute timer will show the end of the cooking time with two series of beeps at an interval of about 20 seconds. In order to switch off the audible alarm you only need press minute timer button "N". The minute timer can be attached to clothing by the clip.

**WARNING: the minute timer does not switch the appliance off.**

### Replacing the minute timer battery

- Remove the minute timer from its compartment (fig. 5).
- Remove the back cover by screw driver (fig. 6).
- Turn the battery cover (fig. 7) placed on the back in an anticlockwise direction until it is released.
- Replace the battery with another of the same type.
- Reassemble the minute timer.

**If the appliance is to be replaced or thrown away, the battery must be removed and disposed of in accordance with the current laws as it represents an environmental hazard.**

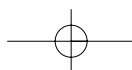



## AFTER FRYING

When the cooking time runs out raise the basket and check if the food has reached the required golden colour. In the models fitted with a viewing window this check can be carried out by looking through the window without opening the lid.

If you consider the cooking to be finished, switch off the appliance by turning the thermostat knob to the "OFF" position until you hear the click of the internal switch.

Allow the excess oil to drip off by leaving the basket in the deep fryer in the raised position.

Note: If the cooking needs to be done in two phases (e.g. potatoes) raise the basket at the end of the first phase and wait for the signal lamp to switch off again. Then immerse the basket back in the oil for a second time (see enclosed tables).

## FILTERING THE OIL OR FAT

We recommend that you carry out this procedure each time you have finished frying especially when the food has been breaded or floured. The food particles tend to burn if they remain in the liquid thus causing much quicker deterioration of the oil or fat.

### WARNING

***Never empty the deep fryer by tilting it or turning it upside down.***

**Check that the oil is cool enough, waiting about 2 hours.**

Bring the deep fryer towards the edge of the work surface **and be careful that feet "L" are always inside the area of the work surface (fig. 8).**

1. Open the lid of the deep fryer and remove the basket.
2. Open door "S" (as in fig. 9).
3. Extract drainage pipe "O".
4. Remove plug "K" while at the same time squeezing the pipe with two fingers to prevent the oil or fat from leaking out before the pipe has been directed into a container (fig. 9).
5. Allow the oil or fat to drip into a container (fig. 10).
6. Remove any deposits from the tank using a sponge or absorbent paper.
7. At the end of the procedure fit the plug back onto the drainage pipe and reposition it in its compartment.
8. Put the basket back in the high position and place one of the filters supplied at the bottom of the basket (fig. 12). You can obtain the filters from your retailer or one of our service centres.
9. Next pour the oil or fat very slowly into the deep fryer so that it does not spill out of the filter (fig. 13).
10. The oil which has been filtered in this way can be preserved inside the deep fryer. However, if a long time elapses before it is next used, it is advisable to preserve the oil in a closed container in order to stop it deteriorating. It is good practice to keep oil used for frying fish separate from that used for frying other food.

\* ***In the event of solid fat or lard being used, be careful not to let it cool down too much or it will solidify.***

## REPLACING THE ANTI-ODOUR FILTERS

With time the anti-odour filters placed inside the lid lose their effectiveness. A change of colour in the filter, visible through hole "A" of fig.14 on the inside cover, shows that the filter needs to be changed. To replace it, remove plastic filter cover "F" (fig.15) by pressing hook "H" in the

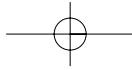

direction of arrow 1, then raise it in the direction of arrow 2. Replace the filters.

**N.B:** The white filter must rest on the metal part (fig.16) and the coloured area must face upwards (towards the black filter).

Reassemble the filter cover, being careful to insert the front hooks correctly (as shown in fig.16).

**Do not run the appliance with exhausted filters as this could cause bad odours and obstruct the steam.**

## CLEANING

Before cleaning, always remove the plug from the electrical socket.

\* ***Never immerse the deep fryer in water or hold it under the tap. By getting inside the water would cause short circuiting and electric shocks.***

**After having appropriately allowed the oil to cool for about 2 hours**, empty out the oil or fat as previously described in the paragraph headed "filtering the oil or fat".

Remove the lid by pulling it gently frontwards (see arrow "1" fig. 14) and pulling upwards (see arrow "2" fig. 14).

Do not immerse the lid in water without having first removed the filters.

To clean the fryer bowl, proceed as follows:

- Clean the fryer bowl pan with hot water and washing up liquid, then rinse and dry carefully. It's a good idea to place the fryer on the sink drainer with the hose draining into the sink. A jug of hot soapy water and soft brush can then be used to clean the fryer bowl, with dirty water draining into the sink (fig. 17).
- In order to clean the inside of the drainage pipe, use the pipe brush supplied (fig. 18). Never use the pipe brush before extracting the drainage tube.
- We advise regular cleaning of the basket, with care being taken to eliminate any deposits.
- Dry the outside of the deep fryer with a soft, damp cloth in order to get rid of splashes and any little dribbles of oil or condensation.
- Clean and dry the seal as well in order to avoid it sticking to the fryer bowl when the product is not in use. (To open the lid in the event of sticking, you only need to raise the lid by hand while at the same time keeping the opening button pressed down).
- **After washing, dry thoroughly. Remove any water left in the bottom of the container and, in particular, inside the oil drainage pipe. This avoids dangerous spurts of hot oil during use.**
- The basket "B" can be washed in a dishwasher.

## MODEL WITH NON-STICK BOILER PAN

To clean the boiler pan use a soft cloth with a neutral detergent never use abrasive detergents.

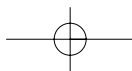

## COOKING HINTS

### HOW LONG THE OIL OR FAT LASTS

The oil or fat must never go below the minimum level. From time to time it is necessary to renew it completely. The length of time the oil or fat lasts depends on what is fried.

Food in breadcrumbs, for example, contaminates the oil more than simple frying.

As for all types of deep fryer, the oil deteriorates if it is reheated several times! Therefore, even if it is used and filtered correctly, we recommend replacing it completely fairly often.

We advise that the oil be completely changed after every 5/8 uses or it should be completely changed in the following circumstances:

- unpleasant odour
- smoke when frying
- oil becomes dark in colour

### HOW TO FRY CORRECTLY

- It is important to follow the recommended temperature for every recipe. If the temperature is too low, the fried food absorbs oil. If the temperature is too high a crust quickly forms on the outside while the inside remains uncooked.
- **The food which is to be fried must only be immersed when the oil has reached the right temperature, i.e. when the signal lamp goes out.**
- Do not overfill the basket. This would cause the temperature of the oil to drop suddenly, resulting in fried food which is too greasy and not uniformly fried.
- When frying small quantities of food, the temperature of the oil must be set lower than the temperature indicated to avoid the oil boiling too violently.
- Check that the food is thinly sliced and of even thickness, as food which is too thick cooks badly on the inside, despite looking cooked, while food of an even thickness reaches the ideal cooking point all at the same time.
- **Dry the food completely before immersing it in the oil or fat**, as wet food becomes soggy after cooking (especially potatoes). It is advisable to bread or flour food which has a high water content (fish, meat, vegetables), being careful to remove the excess bread or flour before immersing it in the oil.

### FRYING NON-FROZEN FOOD

Type of food		Max. Quantity	Temperature °C	Time in Minutes
CHIPS	Half portion	600	170	1st Phase 7-9 2nd Phase 3-5
	MAX quantity (safety limit) whole quantity	1250	190	1st Phase 11-13 2nd Phase 3-4
FISH	Squid	550	160	9-10
	Scampi tails	600	160	8-11
	Sardines	450	160	10-12
	Sole (2 pieces)	400	160	7-9
MEAT	Pig cutlets (3-4 pieces)	350	170	7-9
	Chicken cutlets (3-4 pieces)	350	180	6-8
	Meat balls (15 pieces)	600	170	7-9
VEGETABLES	Onions rings	400	170	6-8
	Cauliflower	450	150	7-9
	Mushrooms	450	150	7-9
	Aubergines	350	150	8-10
	Courgettes	400	150	9-11

Bear in mind that the cooking times and temperatures are approximate and must be adapted according to personal appetite and taste.

### FRYING FROZEN FOOD

- Frozen foods have very low temperatures. As a result they inevitably cause a considerable drop in the temperature of the oil or fat. To achieve a good result, we advise you not to exceed the quantities recommended in the following table.
- **Frozen foods are often covered in ice crystals which must be removed before cooking. This can be done by shaking the basket.** Then immerse the basket very slowly into the frying oil to avoid the oil reboiling.

The cooking times are approximate and must be varied according to the initial temperature of the food which is to be fried and according to the temperature recommended by the frozen food producer.

Type of food	Max. Quantity	Temperature °C	Time in Minutes
CHIPS Recommended quantity for excellent frying	330 (*)	190	5-6
POTATOES CROQUETTES	600	190	6-7
FISH Cod fingers Shrimps	400 400	190 190	5-6 4-5
MEAT Chicken cutlets (n. 3)	300	190	4-5

**WARNING: Before immersing the basket, check that the lid is firmly closed.**

(\*) This is the recommended quantity to achieve excellent frying. It is naturally possible to fry a larger amount of chips, but you should bear in mind that in this case they will end up being a little greasier because of the sudden drop in the oil temperature at the time of immersion.

### OPERATING FAULTS

FAULT	CAUSE	REMEDY
Bad smell	The anti-odour filter is saturated. The oil has deteriorated. The cooking liquid is unsuitable.	Replace the filters. Replace the oil or fat. Use a good quality sunflower or vegetable oil oil.
The oil overflows	The oil has deteriorated and causes too much foam. You have immersed food which is not sufficiently dry in the hot oil. The basket has been immersed too quickly. The oil level in the deep fryer is over the maximum limit.	Replace the oil or fat.  Dry the food well.  Immerse it slowly. Reduce the amount of oil in the fryer bowl.
Food does not brown during cooking	Oil temperature is too low. The basket is over loaded	Select a higher temperature. Reduce a food quantity.
The oil does not heat up	The deep fryer has previously been used without oil in the fryer bowl, causing the thermal safety device to break.	Contact the Service Centre (the device must be replaced).