

Proudly distributed by
De'Longhi Australia Pty Limited
P.O. BOX 4540
CASULA MALL NSW 2170
Customer Service Ph: 1800 126 659
Fax: 1800 706932
www.delonghi.com.au
e-mail: delonghi@delonghi.com.au

De'Longhi New Zealand Limited
99 Khyber Pass Road
Grafton 1023
Auckland, New Zealand
P.O. Box 58-056 Botany
MANUKAU 2163
Customer Service Ph: 0508 200 300
Fax: 0508 200 301
www.delonghi.co.nz
e-mail: delonghi@delonghi.co.nz

CGH Series

CONTACT-GRILL
Instructions for use



De'Longhi

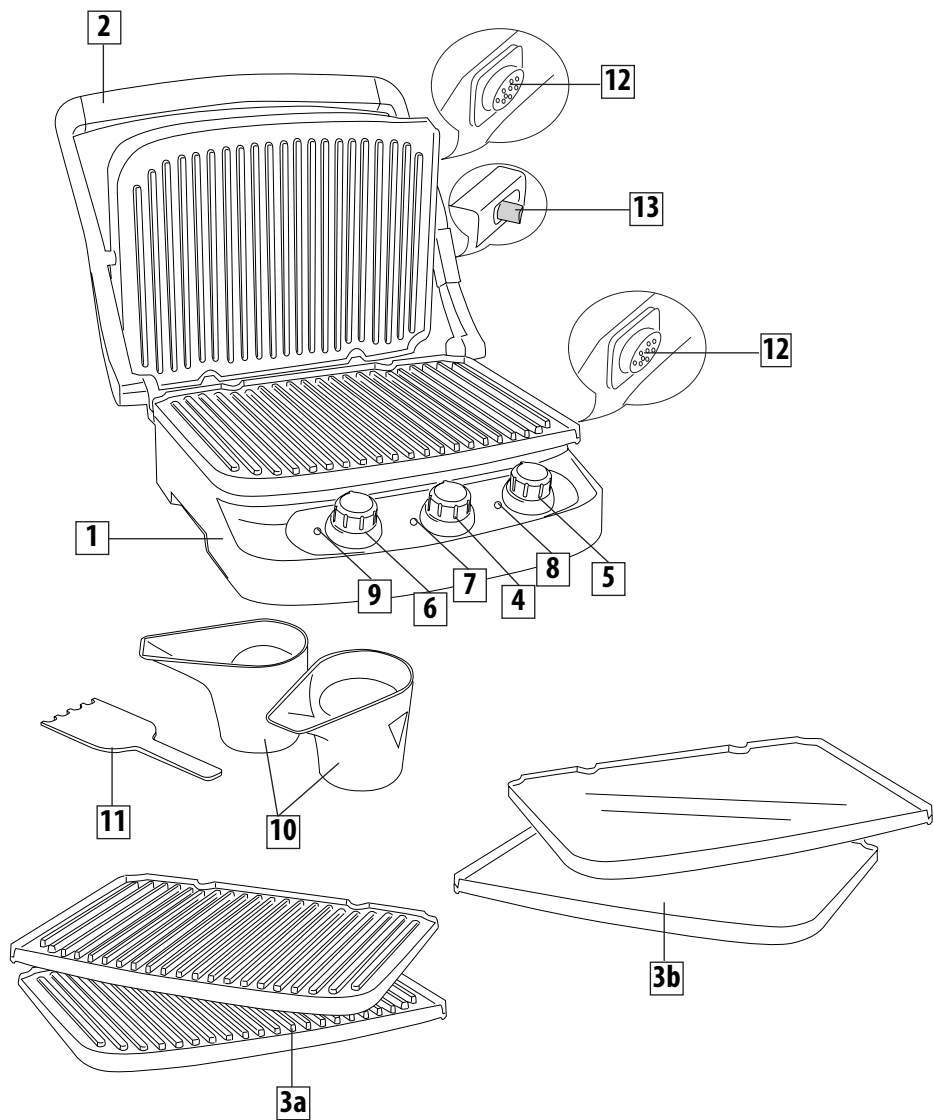

IMPORTANT WARNINGS

Safety warnings



Danger!

Failure to observe the warning may result in life threatening injury by electric shock.

- Before plugging the appliance into the mains, make sure that:
 - The voltage indicated on the appliance rating plate corresponds to your mains voltage;
 - The mains socket is earthed and has a minimum rating of 16A. Failure to follow these important safety instructions absolves the manufacturer of all liability.
- Make sure the power cable does not come into contact with parts of the appliance which become hot during use. If the power cable is damaged, it must be replaced by the manufacturer or the manufacturer's customer services in order to avoid all risk.
- Before putting the appliance away, removing the cooking plates or performing cleaning and maintenance, turn the appliance off by placing the switch in the "0" position and unplugging from the mains.
- Never use the appliance outdoors.
- Never immerse the appliance in water.
- The appliance must not be operated by a timer or a separate remote control system.
- Use extension cables complying with current safety regulations and standards only.
- Never unplug from the mains socket by pulling on the cable.
- Never use the appliance when half open.
- Before plugging the appliance into the mains, make sure the switch is in the "0" position.



Important!

Failure to observe the warning could result in injury or damage to the appliance.

- This appliance is designed to cook food. It must never be used for other purposes, modified or tampered with in any way.
- This is a household appliance only. It is not intended to be used in: staff kitchen areas in shops, offices and

other working environments; farm houses; by clients in hotels, motels and other residential type environments; bed and breakfast type environments.

- This appliance can be used by children aged from 8 years and above and persons with reduced physical, sensory or mental capabilities or lack of experience and knowledge if they have been given supervision or instruction concerning use of the appliance in a safe way and understand the hazards involved. Children shall not play with the appliance.
- Cleaning and user maintenance shall not be made by children unless they are aged from 8 years and supervised.
 - Keep the appliance and its cable out of the reach of children aged 8 and younger.
- Do not leave the appliance within reach of children or unattended while in operation.
- Never use the appliance without the cooking plates.
- Wait until the appliance is completely cold before putting away.
- Do not move the appliance during use.



Danger of burns!!

Failure to observe the warning could result in burns or scalds.

- When the appliance is in operation, the outside may become very hot. Always use the handgrip (2) or oven gloves if necessary.
- Remove or change the cooking plates when the appliance has cooled down.



Please note:

This symbol indicates recommendations and important information for the user.

- To avoid the risk of fire, do not cook food wrapped in plastic film or tinfoil or in plastic bags.

DESCRIPTION (page 2)

- 1. Base and cover:** solid stainless steel structure with self-adjusting cover.
- 2. Handgrip:** strong cast metal handgrip to adjust the cover according to the thickness of the food.
- 3. Removable plates:** non-stick, dishwasher safe, easy to clean.
 - a. Grill plates:** perfect for grilling steak, hamburger, chicken and vegetables.
 - b. Griddle plates:** to prepare perfect pancakes, eggs, bacon and shellfish.
- 4. Mode selector:** contact grill, barbecue grill, griddle plates.
- 5. Contact grill thermostat dial:** adjusts temperature from 80 to 230°C.
- 6. Griddle plate thermostat dial:** adjusts temperature from positions 1 to 5.
- 7.** ON light.
- 8.** Contact grill ready light.
- 9.** Ready light.
- 10. Grease drip cups:** collect the grease, dishwasher safe.
- 11. Cleaning tool:** helps clean the plates after use.
- 12. Plate release buttons:** press to release and remove the plate.
- 13. Hinge release lever:** enables the cover to be fully opened to cook in the flat position.

USE

When using the appliance for the first time

Remove all packaging and labels from the plate. Before throwing the packing material away, make sure you have removed all parts of the new appliance. We recommend you keep the box and packing to re-use in the future.

i **Please note:** the grease drip cups are outside the polystyrene insert.

Before use, clean the base, cover and dials with a damp cloth to remove dust accumulated during transport.

Clean the cooking plates, grease drip cups and cleaning tool thoroughly. The plates, grease drip cups and spatula are dishwasher safe.

Contact grill (use the grill plate)

The contact grill is ideal for cooking hamburgers, deboned meat and thin meat slices, vegetables and sandwiches.

The "contact" function is perfect to prepare food rapidly and healthily. When you use the contact grill, the food cooks quickly as it is in contact with the plates on both side at once

(see figure).

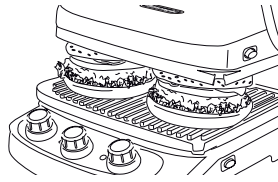

The grease from the food is drained and collected by the grooves on the plate and the hole at the

corner.

When the appliance is used in the "contact" position, we recommend using the grill plates.

Rest the cover evenly on the food until the required cooking temperature is reached.

The appliance has a special handgrip and hinge allowing the cover to be adjusted according to the thickness of the food.

Thinly sliced potatoes and very thick steaks can be prepared with equally perfect results. If you want to cook a number of different types of food simultaneously using the contact grill, the various foods should have the same thickness to allow the cover to be closed evenly.

Barbecue mode with grill plate (use the grill plate)

The appliance can be used as a grill/barbecue to prepare hamburgers, steak, chicken (chicken on the bone is not recommended as it does not cook evenly) and fish.

The grill/barbecue mode is the most versatile.

The plates are in the open position, doubling the cooking surface (see figure). You can prepare a number of different

foods on the separate plates without mixing the flavours, or cook more of the same food.

The grill/barbecue position can be used to grill cuts of meat with different thicknesses, each with the preferred level of cooking.

In the grill/barbecue position, the cover is fully open, creating a double flat cooking surface.

In this position, you need to turn the food during cooking. To use the appliance in the grill/barbecue position, insert the grill plates.

Barbecue mode with griddle plate (model CGH902 only)

The appliance can also be used as a griddle plate to prepare pancakes, eggs, cheese, fritters and bacon and sausages for breakfast (see figure). The griddle plate function is ideal

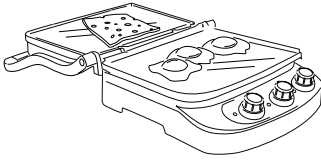

to prepare a fantastic breakfast for two or for all the family. The large cooking surface

enables a number of different foods to be prepared simultaneously, or to cook more of the same food.

When the appliance is used as a griddle plate, the cover must be fully opened to create a double flat cooking surface.

In this position, you need to turn the food during cooking. When using this function, insert the griddle plates.

How to use

When the appliance has been prepared correctly and you are ready to cook, turn the selector to the left to choose the barbecue function with griddle or grill plate, or to the right to choose the contact grill function.

After selecting one of the two positions, the red light comes on to indicate that the appliance is on.

To use the appliance as a contact grill, turn the grill thermostat dial to the required temperature.

You can set a temperature of between 80°C and 230°C.

To use the appliance as a barbecue with griddle plate, turn the griddle plate thermostat dial to the required temperature. You can set it from position 1 to position 5.

The appliance takes up to eight minutes to heat up depending on the set temperature. When the thermostat reaches the required temperature, the green light comes on to indicate the appliance is ready to use.

It is normal for the light to go on and off during use as the thermostat regulates the temperature.

The thermostat dials adjust the temperature of the cooking surface.

The temperature can be varied at any time during cooking, depending on the type of food being prepared.

Take great care when cooking.

To open the appliance, hold the black part of the handgrip which remains cold.

The die-cast aluminium parts become very hot, avoid touching them during and immediately after cooking.

If you need to adjust the position of the cover during cooking, always use an oven glove to avoid burns.

The bottom plate housing is made from plastic and even though it may become very hot, there is no risk of burns.

Before performing any operation on the appliance, leave to cool down for at least 30 minutes.

i Please note: The first time you use the appliance, it may give off a slight odour and a little smoke.

This is normal and common to all appliances with non-stick surfaces.

The appliance is supplied with a black cleaning tool to clean the plates when the appliance has completely cooled down after use (after at least 30 minutes).

If you use the tool for a long time on plates which are still hot, the plastic may melt.

COOKING POSITIONS

Rest the appliance on a clean flat surface where you want to cook.

The appliance can be used in the three following positions:

Closed position - The top plate/cover rests on the bottom plate/base. This is the starting position and also one of the cooking positions when the appliance is used as a contact grill.

Open position - The top plate/cover is open and at 100° with respect to the base. The cover must be opened to this position before using the appliance as a contact grill.

To place the cover in this position, just lift by the handgrip until you hear a click. The cover automatically adjusts to the thickness of the food on the plate. The cover remains in the open position until the handgrip is lowered. This releases the cover which is lowered until it covers the foods to be cooked. The food will thus be cooked evenly on both sides.

When the handgrip is raised after cooking, the cover remains parallel to the base.

To bring it back to the vertical, after removing the food, close and re-open the appliance.

Flat position (fully open) - The top plate/cover is level with the bottom plate/base.

The bottom and top plates are both at the same level, forming a large cooking surface.

In this position, the appliance can be used in barbecue mode with either the grill plate or the griddle plate.

To place the appliance in this position, first identify the hinge release lever on the right. Hold the handgrip with the left hand and with the right, slide the release lever towards you.

Push the handgrip backwards until the cover rests upside down on the work surface. The appliance will remain in this position until the cover is closed again. If the appliance is in the open position and you want to place it in the flat position, pull the handgrip gently towards you and lift the hinge

release lever. Push the handgrip backwards until the cover rests upside down in the flat position.

Lifting the handgrip slightly before pulling the release lever lightens pressure on the hinge and facilitates the operation.

Inserting the cooking plates

Place the appliance in the flat position (see above) with the controls in front of you. Insert one plate at a time.

Each plate can be inserted in either the top or bottom housing only and they are labelled "top" or "bottom".

Lift the bottom grill with the housing for the heating element facing downwards. Looking at the grill, the grease drain hole must be in the front right corner. Identify the metal supports at the centre of the housing. Tilt the back of the plate and line up the shape on the back of the plate with the metal supports. Slide the plate on the supports and push the front of the plate downwards until it clicks into place.

Turn the appliance and insert the top plate, following the same procedure.

To remove the plates

Place the appliance in the flat position (see above).

Identify the plate release buttons on one side.

Push the button decisively to eject the plate from the base.

Hold the plate with both hands, slide it along the metal supports and remove it from the base.

Press the other release button to remove the second plate, following the same operations.



Remove or change the cooking plates when the appliance has cooled down.

Positioning the grease drip cups

When the appliance is used as a contact grill, only one of the grease drip cups is needed.

During cooking, place the cup directly under the grease drain hole. The grease coming from the food is drained towards the hole in the plate and gathered in the cup.

After cooking, dispose of the grease collected appropriately.

The grease drip cups are dishwasher safe.

When the appliance is used as a grill/barbecue or griddle plate, both cups must be used.

Place a cup under the grease drain hole at the end of each of the plates. Once the appliance has been prepared, plug the appliance into a mains socket.

You can now start cooking.

CLEANING AND MAINTENANCE

User maintenance

- Never use metal implements which could scratch the non-stick plates. Use wood or heat-resistant plastic implements.
- Never leave plastic implements in contact with the hot plates, including the cleaning tool supplied.
- Between cooking one food and the next, remove food residues through the grease drain hole and collect them in the grease drip cup, then clean with kitchen paper and move on to the next cooking operation.
- Before cleaning, always leave the appliance to cool down for at least 30 minutes.

Cleaning and care



Please note: Before cleaning the appliance, make sure it has cooled down completely.

At the end of cooking, turn the selector to the "0" position and unplug from the mains.

Leave the appliance to cool down for at least 30 minutes.

Use the special tool supplied to remove any food residues from the plates. The tool can be washed by hand or in the dishwasher. Empty the grease drip cups. The grease drip cups can be washed by hand or in the dishwasher.

Press the plate release buttons to remove the plates from the appliance. Before touching them, make sure they have cooled down completely (wait at least 30 minutes).

The cooking plates are dishwasher safe. Frequent washing could reduce the properties of the ceramic coating.

Do not use metal objects to clean the plates.