

DESCRIPTION OF THE APPLIANCE

- A Thermostat knob
- B Timer knob
- C Indicator light
- D Function selector knob
- E Glass door
- F Bottom heating element
- G Wire rack
- H Bake pan
- I Spit (if supplied)

- L Crumb tray
- M Top heating element
- N Interior light (if supplied)
- O Turnspit mount (if supplied)
- P Broil rack (if supplied)
- Q Handgrip for spit (if supplied)

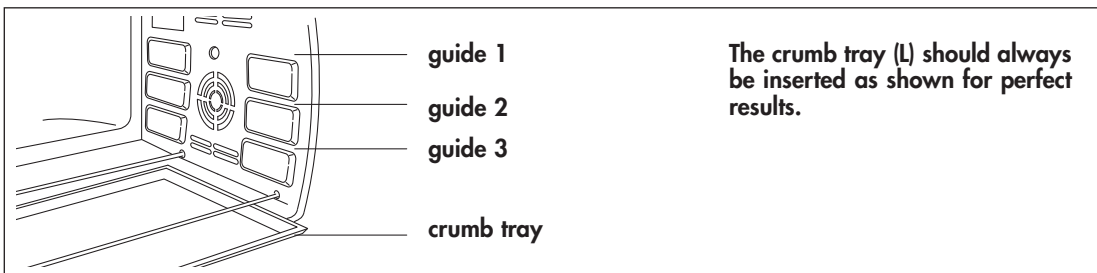
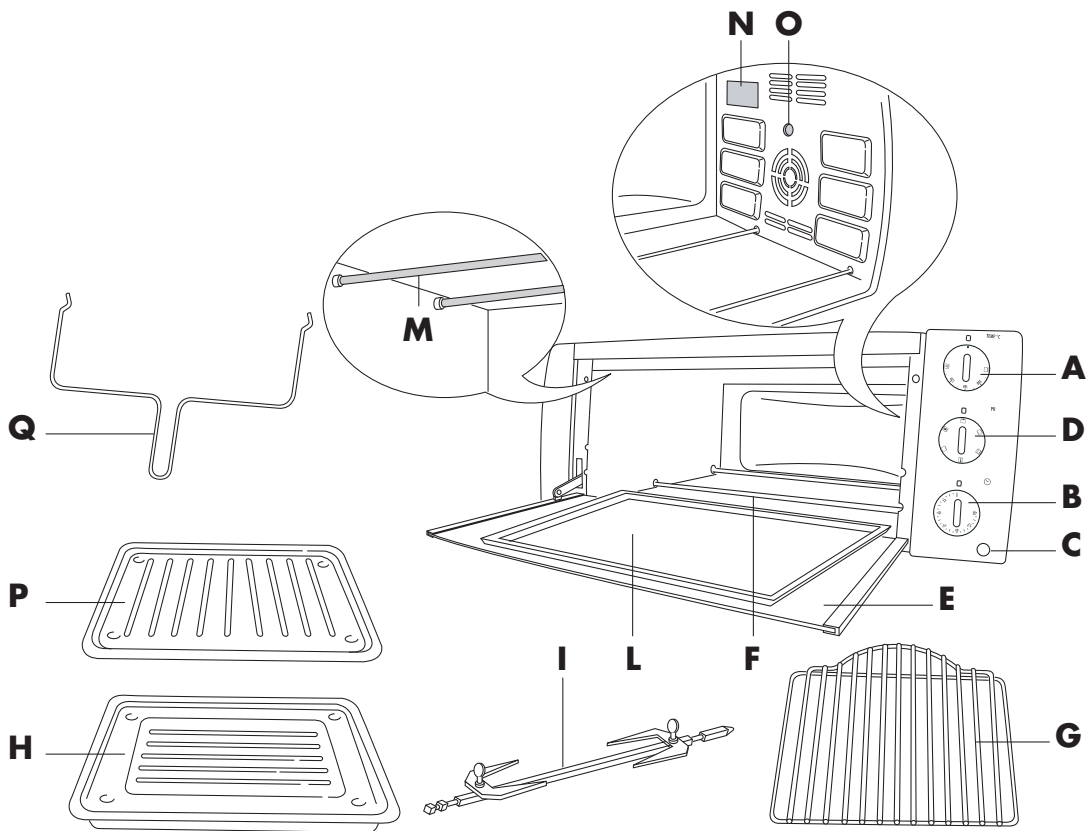

SPECIFICATIONS

Operating voltagesee rating label

Maximum power absorbedsee rating label

POWER CONSUMPTION (CENELEC STANDARD HD 376)

To reach 200°C0,09 KWh

To maintain 200°C for one hour0,58 KWh

Total0,67 KWh

This appliance conforms to EC directive 2004/108/EC on Electromagnetic Compatibility and EC regulation no. 1935/2004 of 27/10/2004 on materials intended for contact with food.

WARNINGS

- **Read all the instructions carefully before using the appliance.**
- This oven has been designed to cook food. It must never be used for other purposes, modified or tampered with in any way.
- Place the appliance on a horizontal surface at a height of at least 85 cm and out of reach of children.
- Wash all accessories thoroughly before use.
- **Before plugging into the mains, make sure that:**
 - **the mains voltage corresponds to the voltage indicated on the rating plate;**
 - **the mains socket has a minimum rating of 16A and an earth wire.**
- **The manufacturer declines all liability in the event that this important accident-prevention rule is not respected.**
- Before using the oven for the first time, remove any paper and other material inside the oven such as protective cardboard, booklets, plastic bags, etc.
- Before using for the first time, operate the oven empty with the thermostat at maximum for at least 15 minutes to eliminate the "new" smell and any smoke caused by the presence of protective substances applied to the elements before transport.
During this operation, ventilate the room.
- **IMPORTANT:** when you have unpacked the appliance, make sure the door is undamaged and working correctly. The door is made from glass and is therefore fragile. If it is visibly chipped, scored or scratched, it should be replaced. While using, cleaning or moving the appliance, avoid slamming or knocking the door violently. Do not pour cold liquid onto the glass while the appliance is hot.
- **When in operation, the door and accessible external surfaces could become very hot. Always use the knobs, handles and buttons. Never touch metal parts or the glass. Use oven gloves if necessary.**
- **This electrical appliance operates at high temperatures which could cause burns.**
- Accessible parts may become hot during use. Young children should be kept away.
- The appliance is not intended for use by persons (including children) with reduced physical, sensory or mental capabilities, or lack of experience and knowledge, unless they have been given supervision or instruction concerning use of the appliance by a person responsible for their safety. Children should be supervised to ensure that they do not play with the appliance.
- Do not move the appliance while in use.
- Do not use the appliance if...
 - the power cable is faulty,
 - the appliance has been dropped, is visibly damaged or malfunctions.
- Should this occur, to avoid all risk take the appliance to your nearest authorised service centre.
- Do not let the power cable dangle and avoid touching hot parts of the oven. Never unplug the appliance by pulling on the power cable.
- If you intend to use an extension, make sure it is in good condition, that the plug is earthed and that the



cross section of the wires is at least equal to that of the power cable provided with the appliance.

- To avoid all risk of electric shock, never immerse the power cable, plug or appliance itself in water.
- Never position the appliance near heat sources.
- Do not leave inflammable products near the oven or under the work surface where it is located.
- Bread may burn. Never leave the oven unattended during toasting or grilling. Never operate the appliance under a wall cupboard or shelf or near inflammable materials such as curtains, blinds, etc.
- Do not use the appliance as a heat source.
- Never place paper, cardboard or plastic inside the oven and never rest anything on top of the appliance (utensils, wire racks, other objects).
- Never insert anything into the ventilation openings. Make sure they are unobstructed.
- **If food or other parts of the oven catch fire, never try and put out the flames with water. Close the door, unplug from the mains and smother the flames with a damp cloth.**
- This oven is not designed for built-in installation.
- When the door is open, remember:
 - never exert excessive pressure with overly heavy objects or pull the handle downwards;
 - never rest heavy containers or boiling saucepans just out of the oven on the open door.
- Given the differences in legislation in force, if the appliance is used in a country other than that where it was bought, have it checked by an authorised service centre.
- For your personal safety, never take the appliance to pieces on your own. Always contact an authorised service centre.
- This appliance is designed for domestic use only. Professional or inappropriate use, or failure to observe the instructions absolves the manufacturer from all responsibility and invalidates the guarantee.
- When not in use and before cleaning, always unplug the appliance.
- If the supply cord is damaged, it must be replaced by the manufacturer, its service agent or similarly qualified persons in order to avoid a hazard.
- Do not use harsh abrasive cleaners or sharp metal scrapers to clean the oven door glass since they can scratch the surface, which may result in shattering of the glass.
- Appliance is not intended to be operated by means of an external timer or separate remote-control system.
- The appliance must be placed to work with the rear side approached to the wall.

Keep these instructions

ELECTRICAL CONNECTION (UK ONLY)

- A) If your appliance comes fitted with a plug, it will incorporate a 13 Amp fuse. If it does not fit your socket, the plug should be cut off from the mains lead, and an appropriate plug fitted, as below.
WARNING: Very carefully dispose of the cut off plug after removing the fuse: do not insert in a 13 Amp socket elsewhere in the house as this could cause a shock hazard.
With alternative plugs not incorporating a fuse, the circuit must be protected by a 15 Amp fuse.
If the plug is a moulded-on type, the fuse cover must be re-fitted

IMPORTANT

The wires in the mains lead are coloured in accordance with the following code:

Green and yellow:	Earth
Blue:	Neutral
Brown:	Live



As the colours of the wires in the mains lead may not correspond with

when changing the fuse using a 13 Amp Asta approved fuse to BS 1362. In the event of losing the fuse cover, the plug must NOT be used until a replacement fuse cover can be obtained from your nearest electrical dealer. The colour of the correct replacement fuse cover is that as marked on the base of the plug.

- B) If your appliance is not fitted with a plug, please follow the instructions provided below:

WARNING - THIS APPLIANCE MUST BE EARTHED



















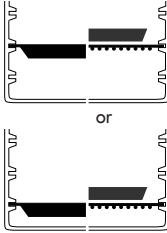

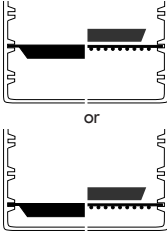
the coloured markings identifying the terminals in your plug, proceed as follows:

The green and yellow wire must be connected to the terminal in the plug marked with the letter E or the earth symbol  or coloured green or green and yellow.

The blue wire must be connected to the terminal marked with the letter N or coloured black.

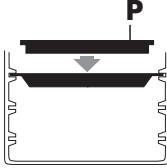
The brown wire must be connected to the terminal marked with the letter L or coloured red.



SUMMARY TABLE

Program	Function selector knob position	Thermostat knob position	Wire rack and accessory position	Notes/Tips
Defrost <i>(only on some models)</i>				1 2 3 Place the food directly on the wire rack inserted in the guide 2.
Delicate cooking		100°C-220°C		1 2 3 Use the bake pan inserted directly in the guide 3.
Keeping warm				1 2 3 Select this function to keep hot food warm. Do not hold food for longer than one hour or rewarm cold food at this setting. If food is not hot enough for serving turn temperature dial up.
Convection oven cooking <i>(only on some models)</i>		100°C-220°C		1 2 3 Ideal for lasagna, meat, pizza, cakes in general, foods that should be crunchy on the surface ("au gratin") and bread. For details on how to use the accessories, refer to the tips in the table on pages 18.
Traditional oven cooking		100°C-220°C		1 2 3 Ideal for cooking stuffed vegetables, fish, plum cakes and small poultry. For details on how to use the accessories, refer to the table on page 18.
Toast				1 2 3 Ideal for toasting slices of bread.
Grilling				1 2 3 Put the broil rack (P) (if supplied) on the bake pan (H); place the food on the pan and insert into guide 1. Ideal for broiling meat, fish and vegetables.
Grilling with the turnspit <i>(only on some models)</i>				1 2 3 Insert the spit in the turnspit mount (O) as described on page 20. Insert the bake pan in guide 3. Ideal for poultry, beef, etc.

USING THE CONTROLS

Thermostat knob (A)

Select the desired temperature, as follows:

- To defrost (*only on some models*) (see page 17): ...Thermostat knob in the "•" position.
- To keep food warm (see page 17):Thermostat knob in the  position.
- For convection oven cooking (*only on some models*)
or traditional oven cooking (see page 17-18):Thermostat knob from 100°C - 220°C..
- To toast (see page 19):Thermostat knob in the  position.
- For all types of grilling (see page 20):Thermostat knob in the  position.

Timer knob (B)

- To switch the oven on:Rotate the knob in a clockwise direction.
- To switch the oven off:Turn the knob back to the "0" position.

Function selector knob (D)

This knob is used to select the cooking functions available, which are:

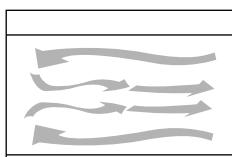

(*only on some models*)
(ventilation only)

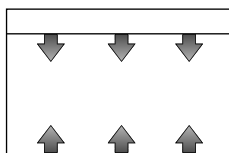

(only top heating element
and bottom heating element
on)

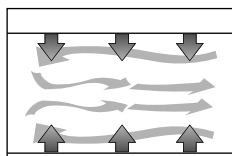

(*only on some models*)
(top heating element, bottom heating
element and ventilation on)

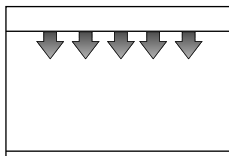

(solo resistenza superiore in
funzione alla massima
potenza)

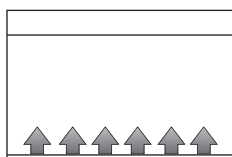

(only bottom heating element
on)

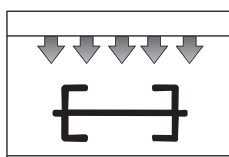

(*only on some models*)
(only top heating element on
at maximum power + turn-
spit)

Interior light (N) (*only on some models*) and Indicator light (C)

When the oven is in function, the indicator light (C) and the interior light (N) (*only on some models*) stay on.

USING THE OVEN

General tips

- When cooking with the convection oven, traditional oven and grilling, always preheat the oven for 5 minutes to the set temperature.
- The cooking times depend on the quality of the products, on the temperature of the food and on personal tastes. The times indicated in the table are subject to variation, and do not include the time required to preheat the oven.
- To cook frozen foods refer to the recommended times on the product packaging.

Defrost (only on some models)

For proper defrosting in a short time, proceed as follows:

- Turn the function selector knob (D) to the  position.
- Turn the thermostat knob (A) to the “•” position.
- Rotate the timer knob (B) in a clockwise direction.
- Place the bake pan (H) in guide 3, the wire rack (G) in the guide 2 and rest the food to be defrosted, then close the door.
- After defrosting, turn the Timer knob (B) back to “0” position.



Example of defrosting: 1 kg of meat, 80-90 minutes without turning it over.

Slow bake

Ideal for pastry and cakes. Good results are also achieved when completing the cooking of the bottom of the foods or for cooking that requires heat above all at the bottom.

- Place the bake pan (H) in guide 3, as shown in the table on page 15.
- Turn the function selector knob (D) to the  position.
- Select the required temperature using the thermostat knob (A).
- Turn the Timer knob (B) in a clockwise direction; after cooking, manually turn the Timer knob (B) back to “0” position.

Keep warm

- Turn the thermostat knob (A) to the  position.
- Turn the function selector knob (D) to the  position.
- Rotate the timer knob (B) in a clockwise direction.
- Place the bake pan (H) in guide 3 and rest the food on the bake pan.
- To end the operation, manually turn the Timer knob (B) back to “0” position.

It is recommended not to leave the foods in the oven for too long, as these may dry out.

Convection oven cooking (only on some models)

This function is ideal for baking excellent pizzas, lasagna, “au gratin” dishes, all types of meat dishes (apart from small poultry), roast potatoes, cakes in general and bread.

Proceed as follows:

- Place the wire rack (G) or the bake pan (H) in the position shown in the table on page 15.
- Turn the function selector knob (D) to the  position.
- Select the required temperature by turning the thermostat knob (A).
- Rotate the timer knob (B) in a clockwise direction.
- After having pre-heated the oven for 5 minutes, place the food to be cooked inside.
- After cooking, manually turn the Timer knob (B) back to “0” position.

Program	Thermostat knob	Times	wire rack/ bake pan position	Comments and tips
Quiche 700 g	200°C	30-35 min.	3	Use the bake pan.
Chicken 1 kg	200°C	60-70 min.	3	Use the bake pan, turn after around 38 min.
Roast pork 900 g	200°C	50-60 min.	3	Use the bake pan, turn after around 30 min.
Meatballs 650 g	200°C	35-40 min.	3	Use the bake pan, turn after around 20 min.
Roast potatoes 500 g	200°C	40-50 min.	2	Use the bake pan, mix twice.
Jam tarts 700 g	180°C	35-40 min.	3	Use a cake dish.
Strudel 1 kg	200°C	35-40 min.	2	Use the bake pan.
Margherita cakes 800 g	180°C	25-30 min.	3	Use a cake dish.
Biscuits (shortbread) 100 g	180°C	15-20 min.	2	Use the bake pan.
Bread 500 g	200°C	20-25 min.	3	Use the bake pan greased with oil.

Bake

This function is ideal for all types of fish, stuffed vegetables, cakes with whipped egg-whites and cakes that require long cooking times (over 60 min.).

Proceed as follows:

- Place the wire rack (**G**) or the bake pan in the position shown in the table.
- Turn the function selector knob (**D**) to the  position.
- Select the required temperature by turning the thermostat knob (**A**).
- Rotate the timer knob (**B**) in a clockwise direction.
- After having pre-heated the oven for 5 minutes, place the food inside.
- After cooking, manually turn the Timer knob (**B**) back to "0" position.

Program	Thermostat knob	Times	wire rack/ bake pan position	Comments and tips
Macaroni "au gratin" 1 kg	200°C	25-30 min.	2	Use an ovenproof dish.
Lasagna 1 kg	200°C	25-30 min.	2	Use an ovenproof dish.
Pizza 500 g	200°C	30-35 min.	3	Use the bake pan.
Trout 500 g	180°C	30-35 min.	3	Use the bake pan, turn after 16 minutes.
Stuffed calamari 450 g	180°C	35-30 min.	3	Use an ovenproof dish, turn halfway through cooking.
Tomatoes "au gratin" 550 g	180°C	35-40 min.	2	Use the bake pan greased with oil and turn after 20 min.
Zucchini with tuna 750 g	180°C	35-40 min.	2	Use the bake pan; add oil, the tomatoes and water; turn the bake pan after 20 min.
Plum cakes 1 kg	180°C	65-75 min.	3	Use a mold and turn halfway through cooking.

Toast

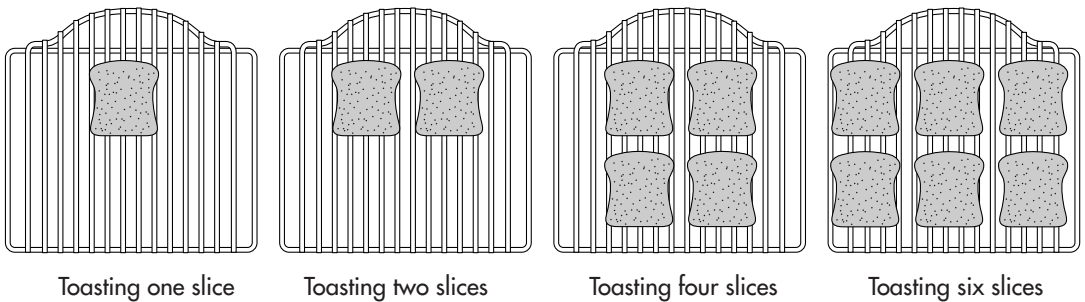

- The dimensions of the wire rack (**G**) allow six slices of bread to be toasted at the same time. Best results are achieved, however, with four slices at a time.
- To toast the bread, place the slices as shown below:



For consecutive uses, reduce the set toasting time.

Instructions for toasting bread

To automatically toast frozen bread, sandwiches, muffins and waffles, always use the wire rack.

1. Place the wire rack in the guide 2.
2. Place the food to be toasted in the center of the wire rack. Close the door.
3. Turn the thermostat knob (**A**) to the  position and the function selector (**D**) to the  position.
4. The Timer knob (**B**) should be turned clockwise. In general, to obtain medium toasting, set the Timer knob (**B**) on 4-5 minutes. Toast a few pieces of bread to verify the time.
5. When toasting bread, both the top and bottom heating elements are on to toast both sides at the same time. A little condensation may form on the inside of the glass door. This is normal. It will disappear during toasting.
6. An audible signal indicates the end of the set time. The toasting is complete and the heating elements automatically switch off. Turn the thermostat knob (**A**) to the "0" position.

Note:

If you prefer lighter toasting, it is sufficient to interrupt the automatic cycle by turning the Timer knob (**B**) to "0" to switch off the oven, causing no damage.

For darker toasting re-start the cycle by turning the Timer (**B**) clockwise until reaching the desired level.

Then manually turn the thermostat knob and the toast timer knob off, as described previously.

The best positions for each type of bread can be identified when using the oven regularly.

Tips for good toasting:

Larger pieces of bread and frozen bread take longer to toast. Just one slice of bread requires a lower setting than for multiple slices.

Broil

- Place the food to be grilled on the broil rack (P) inserted on the bake pan (H), and place them together in the guide 1.
- Close the door until you hear a “click” (see figure 1).
- Turn the function selector knob (D) to the  position.
- Rotate the timer knob (B) in a clockwise direction.
- After cooking, manually turn the Timer knob (B) back to “0” position.
- Turn halfway through cooking.

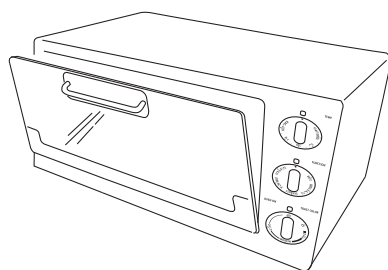





fig. 1

Program	Thermostat knob	Times	Comments and tips
Pork chops (2)		30 min.	Turn after 16 minutes.
Hot dogs (3)	"	20 min.	Turn after 11 minutes.
Hamburgers (2)	"	25 min.	Turn after 13 minutes.
Sausages (4)	"	26 min.	Turn after 14 minutes.
Kebabs 500 g	"	26 min.	Turn after 8, 15 and 21 minutes.

Grilling with the turnspit (only on some models)

This function is ideal for cooking chickens on the spit, fowl in general, roast pork and veal.

The rotisserie function can be used for a load up to 2 kg.

- Place the food on the spit (I) and hold it firm using forks (fig. 2) (for best results, tie the meat using kitchen string).
- Insert the bake pan (H) in the guide 3 and the spit (I) in the turnspit mount (fig. 3).
- Close the door until you hear a “click” (see figure 1).
- Turn the thermostat knob (A) to position .
- Turn the function knob (D) to position .
- Rotate the timer knob (B) in a clockwise direction.

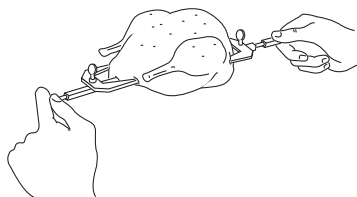

fig. 2

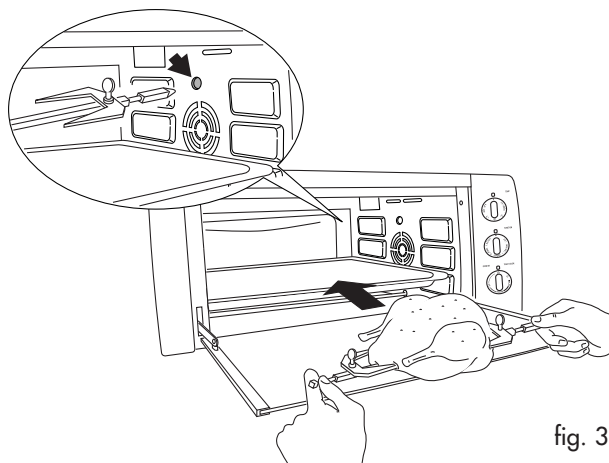

fig. 3

For information on the cooking times, refer to the instructions in the table below.

FOOD	WEIGHT	APPROX. TIME
Chicken	1-2 Kg	120 min.
Rost pork	0,8-1,7 Kg	90 min.

For larger foods, we recommend the convection oven cooking mode.

CLEANING AND MAINTENANCE

Frequent cleaning prevents the formation of smoke and bad odors during cooking. Do not let fat accumulate inside the appliance.

Before any maintenance or cleaning operation, unplug the oven and wait for it to cool down.

Clean the door, the inside walls and the enamel or painted surfaces of the oven with a soap and water solution; dry thoroughly.

To clean the surfaces on the inside of the oven, never use products that corrode aluminum (detergents in spray cans) and never scrape the walls with sharp objects to avoid damage to the non-stick coat.

To clean the outside surface always use a damp sponge.

Avoid using abrasive products that may damage the exterior.

Make sure water or liquid soap does not seep into the vents on the top of the oven.

Do not attempt to push forks, knives or sharp objects into the openings on the right-hand side and the rear of the oven.

Never immerse the appliance in water; never wash it under a jet of water.

All the accessories are washed like normal dishes, either by hand or in the dishwasher.

Slide the crumb tray out from under the bottom of your oven. Wash by hand. Should the soilage be difficult to remove, rinse the crumb tray with hot soapy water and if necessary, scour it delicately, without scratching it.

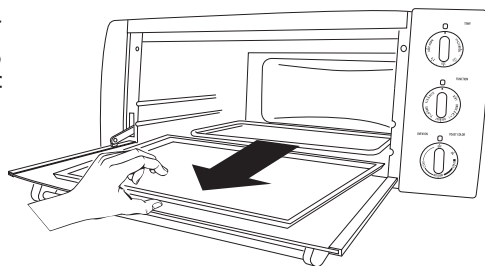
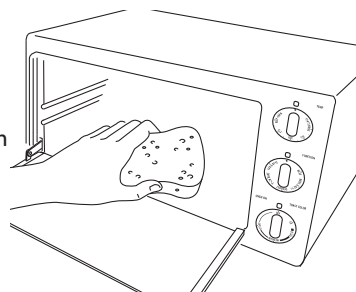
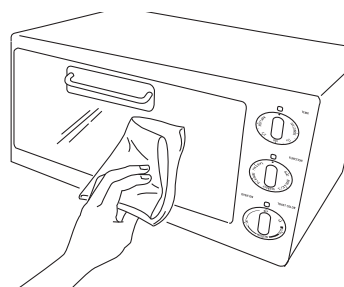

Important information for correct disposal of the product in accordance with EC Directive 2002/96/EC.

At the end of its working life, the product must not be disposed of as urban waste.

It must be taken to a special local authority differentiated waste collection centre or to a dealer providing this service.

Disposing of a household appliance separately avoids possible negative consequences for the environment and health deriving from inappropriate disposal and enables the constituent materials to be recovered to obtain significant savings in energy and resources. As a reminder of the need to dispose of household appliances separately, the product is marked with a crossed-out wheeled dustbin.

