



PORTABLE AIR CONDITIONER

INSTRUCTION FOR USE

MODEL **PAC N76**



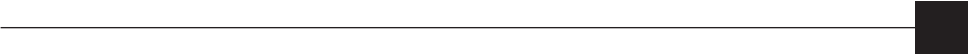

Description

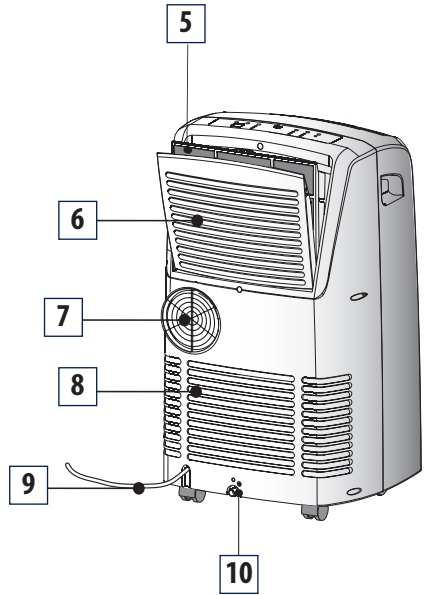
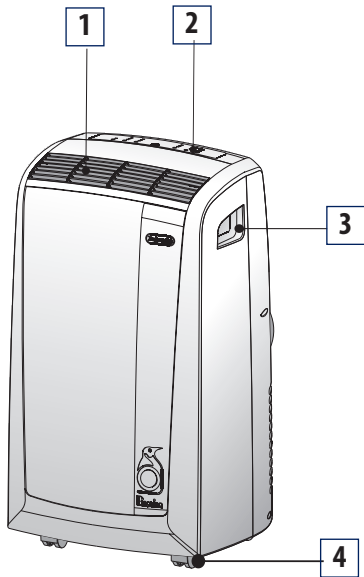

Accessories

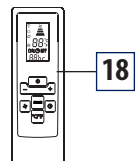
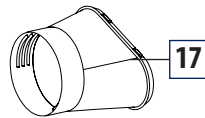
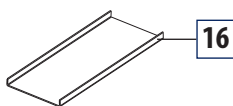
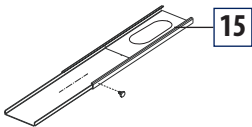
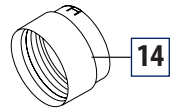
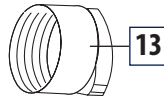
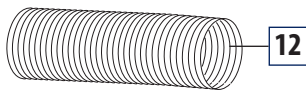
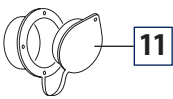

- Use this local air conditioner only as described in this instruction manual.
As with all electrical equipment, whilst the instructions aim to cover as many eventualities as possible, caution and common sense should be applied when operating and installing this appliance.
- This appliance is designed for home air conditioning and must not be used for other purposes.
- It is dangerous to modify or alter the characteristics of the appliance in any way.
- The appliance must be installed in conformity with national legislation regulating electrical equipment and installations.
- If the appliance requires repair, contact a Service Centre authorised by the manufacturer only. Repairs carried out by unauthorised personnel may be dangerous.
- This appliance must be used exclusively by adults.
- This appliance can be used by children aged 8 upwards and by persons with reduced physical, sensory or mental capabilities or who lack of experience and knowledge if they are supervised or have been given instructions concerning use of the appliance in a safe way and understand the hazards involved. Children must not play with the appliance. Cleaning and user maintenance must not be carried out by children unless they are older than 8 and supervised. Keep the appliance and its cord out of the reach of children under 8 years of age.
- The appliance must be connected to an efficient earth system. Have your electrical circuit checked by a qualified electrician.
- Do not use extension cables.
- Before cleaning or maintenance, always unplug the

appliance from the mains socket.

- Never unplug the appliance by pulling on the power cable.
- Do not install the appliance in rooms containing gas, oil or sulphur. Do not install near sources of heat.
- Keep the appliance at least 50 cm away from flammable substances (alcohol etc) or pressurised containers (eg aerosol cans).
- Do not rest heavy or hot objects on top of the appliance.
- Clean the air filter at least once a week.
- Avoid using heating appliances near the air conditioner.
- Always transport the appliance upright or resting on one side.
Before moving the appliance, empty the internal circuit completely of water.
After moving the appliance, wait at least 1 hour before starting it
- When putting the appliance away, do not cover with plastic bags.
- The materials used for packaging can be recycled. You are therefore recommended to dispose of them in special differentiated waste collection containers.
- At the end of its working life, consign the appliance to a specialist collection centre.
- If the power cable is damaged, it must be replaced by the manufacturer or an authorised technical service centre in order to avoid all risk.

SPECIFIC WARNINGS FOR APPLIANCES WITH R410A* REFRIGERANT GAS

R410A refrigerant gas conforms to EC regulations on the environment. Avoid perforating the refrigerant circuit of the appliance.

ENVIRONMENTAL INFORMATION: This unit contains fluorinated greenhouse gases covered by the Kyoto Protocol. Maintenance and disposal must be carried out by qualified personnel only (R410A, GWP=1975).

* Verify the type of refrigerant gas used in your appliance on the rating plate.

DESCRIPTION

- 1** Air outlet grille
- 2** Control panel
- 3** Handles
- 4** Castors
- 5** Filter
- 6** Evaporator air intake grille
- 7** Air exhaust hose housing
- 8** Condenser air intake grille
- 9** Power cable

- 10** Drainage hose with 2 caps
- 11** Wall flange with cap
- 12** Air exhaust hose
- 13** Hose adaptor
- 14** Accessory for wall mounting
- 15** Window bracket
- 16** Additional window bracket
- 17** Window outlet
- 18** Remote control

ELECTRICAL CONNECTIONS

Before plugging the appliance into the mains socket, check that:

- The outlet's power supply corresponds to the value indicated on the rating label on the back of the appliance;
- The outlet and electrical circuit are adequate for the appliance;
- The outlet is a 3-hole grounded outlet . If this is not the case, you must choose another outlet.

Failure to follow these important safety instructions absolves the manufacturer of all liability.

The power cable must be replaced by a qualified professional only.

The instructions below will enable you to prepare your air conditioner for operation as efficiently as possible. **Before use, make sure the air intake and outlet grilles are unobstructed.**

AIR-CONDITIONING WITHOUT INSTALLATION

Just a few simple steps and your comfort is ensured with your air conditioner:

- Screw the hose adaptor **13** to the hose's end **12**.
- Fit the air exhaust hose in the housing at the back of the appliance. Insert it as shown in figure **A**.

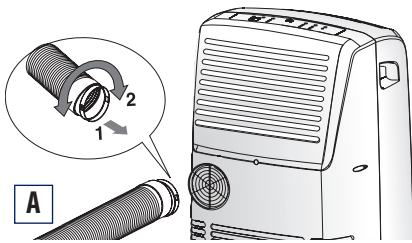

- Screw the window outlet **17** to the other end of the exhaust hose. (see fig. **B**).

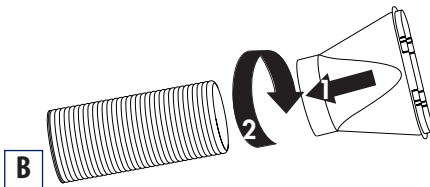

Sash window

- Open the window.
- Place the window bracket **15** in the window, extending it to fit the width of the window (fig. **C**).
- Place the air conditioner near the window. Insert the assembled exhaust hose **12** into the window bracket hole **15**.
- Make sure the air exhaust hose is unobstructed.
- If you have a very large window, in order to cover your window aperture, use the additional window bracket without holes extending it to the desired dimension, then fix the bracket by using the locking pin provided. When extracting the window bracket and joining the two pieces pay attention you do not cover the hole.

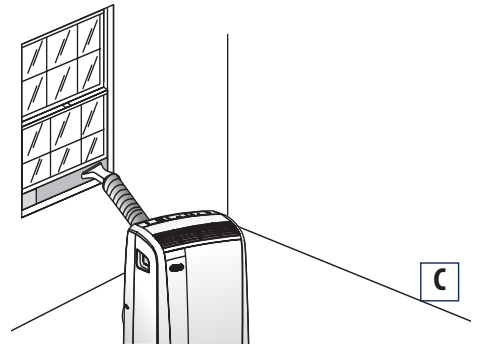

Other set-up methods:

- Thanks to the locking pin, it's possible to use the window bracket also for sliding windows. Position the hole of the bracket so to allow a correct installation of the exhaust hose (see figure **D**).

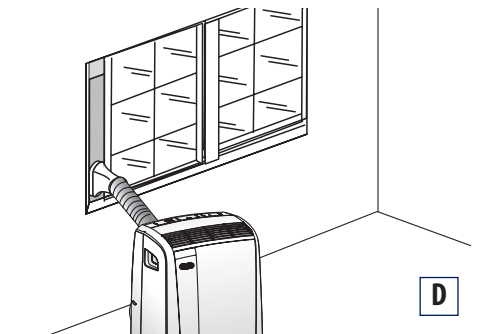

Keep the air hoses as short and free of curves as possible to avoid constrictions.

French window

- After having screwed the window outlet **17** into the air exhaust hose **12**, open the French window slightly and position the window outlet **17** as shown in figure **E**.



E

SEMI-PERMANENT INSTALLATION

If required, your appliance can also be installed semi-permanently (Fig. F).

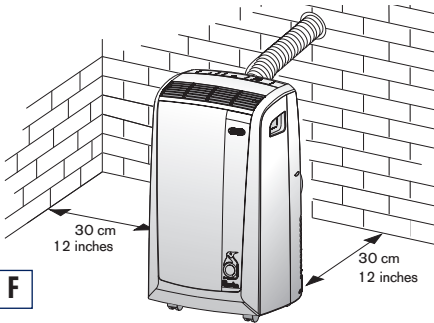

F

Proceed as follows:

- Drill a hole (ø134mm / 5,27 in.) in an outside wall or through a window pane.
Respect the height and dimensions of the hole given in figures **F** and **G**.

NOTE: As special tools are required for installation, we suggest you have the appliance installed by specialized personnel.

KEEP THE AIR HOSES AS SHORT AND FREE OF CURVES AS POSSIBLE TO AVOID CONSTRICTIONS.

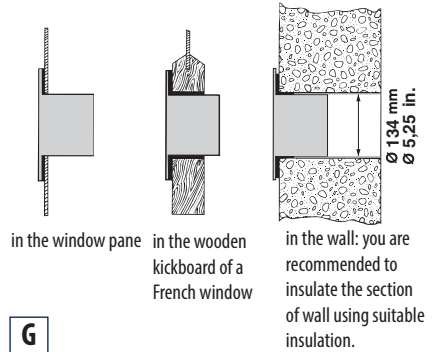

G

- Fit the wall flange **11** into the hole.
- Screw the hose adaptor **13** to the hose's end **12**.
- Fit the air exhaust hose in the housing at the back of the appliance as shown in figure **A**.
- Screw the wall mounting accessory **14** into the hose **12**. (fig. **H**) and fit it into the wall flange **11** as shown in fig. **I**.

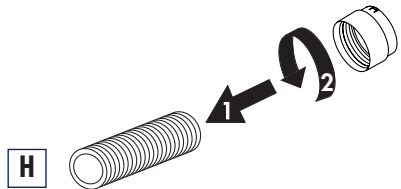

H

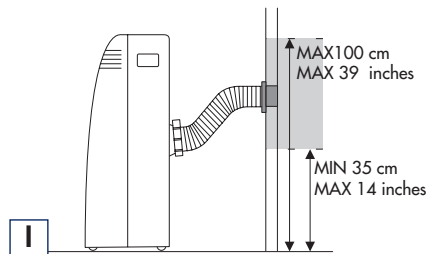

I

When the hose **12** is not fitted, the hole can be closed with the flange cap **11**.

NOTE: When installing the air conditioner semi-permanently, you should leave a door slightly open (as little as 1 cm) to guarantee correct ventilation.

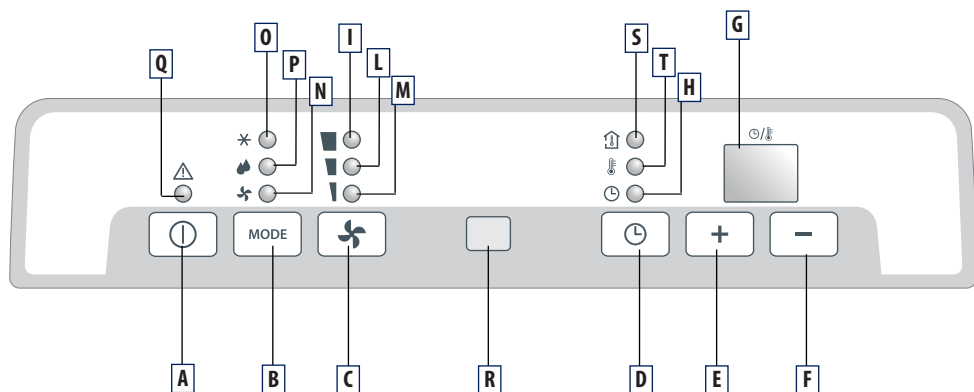

DESCRIPTION OF THE CONTROL PANEL

- A ON/OFF button**
- B MODE selection button**
Air conditioning, dehumidifying, fan.
- C Fan speed selection button (MAX/MED/MIN)**
- D Timer button**
- E Programmed operation increase temperature/time button**
- F Programmed operation decrease temperature/time button**
- G Display** Displays the temperature values set and the programmed operating time
- H Timer in operation indicator light**
- I/L/M Fan speed lights**
- N Fan mode light**
- O Air-conditioning mode light**
- P Dehumidifying mode light**
- Q Alarm light**
- R Remote control receiver**
- S Light: displays room temperature**
- T Light: displays set temperature**

Never turn the air conditioner off by unplugging from the outlet. Always press the  button, then wait for a few minutes before unplugging. This allows the appliance to perform a cycle of checks to verify operation.

TURNING THE APPLIANCE ON

Before plugging the appliance check the caps on the back of the unit are correctly inserted and screwed on the drainage hose 10.

Plug into an outlet. Two lines appear on the display indicating that the appliance is in stand-by. Press the **ON/STAND-BY** button (A). When turned on, the air conditioner starts operating in the same mode as when it was turned off. Press the **MODE** button (B) until the light corresponding to the desired mode lights up:

- Light (O): **air-conditioning** mode
- Light (P): **dehumidifying** mode
- Light (N): **fan** mode

AIR CONDITIONING MODE

Ideal for hot muggy weather when you need to cool and dehumidify the room.

The display shows the inner temperature: the light (S) turns on.

To modify the set temperature, push the (E) or (F) button to reach the desired temperature. The (T) light turns on and the (S) light turns off. (To change from °F to °C or viceversa, press for few seconds both button E and F).

After 15 seconds, the inner temperature is shown on the display.

The (S) light turns on.

You can adjust the temperature only in air conditioning mode. Then select the fan speed by pressing the **FAN button (C)** until the light corresponding to the required fan speed lights up:

- MAX:** the air conditioner operates at maximum to achieve the target temperature as rapidly as possible
- MED:** reduces noise levels while maintaining a comfortable temperature
- MIN:** for silent operation

The most suitable temperature for the room during the summer varies from 75°F to 81°F (24 to 27°C). You are recommended, however, not to set a temperature much below the outdoor temperature.

FAN MODE

Adjust fan speed by pressing the **FAN button (C)** as described for the air-conditioning mode.

Remember that the higher the speed, the more air is filtered. If you select "MIN" speed, less air is filtered but the appliance is also less noisy.

DEHUMIDIFYING MODE

Ideal for reducing the humidity in a room without lowering or raising the temperature (spring or autumn, damp rooms, rainy spells, etc). When the dehumidifying mode is selected, the light (P) comes on. At the same time, the "MIN" fan speed light (M) comes on. In this mode, other speeds cannot be selected.

PROGRAMMING THE TIMER

The timer can be used to delay appliance start up or shut down. This avoids wasting electricity by optimising operating periods.

How to programme delayed start up

- Plug the appliance into a mains socket and press the ON/OFF button (A), then select the required operating mode and other settings (temperature, fan speed, etc).
- Press the ON/OFF button (A) again to place the appliance in standby mode.
- Press the timer button (D). The timer light "H" flashes.
- Use the + (E) or - (F) buttons to set the number of hours delay before the appliance comes on. The time increases or decreases in steps of one hour.

The indicator light (H) flashes until the appliance starts up.

You can set the appliance to come on with a delay of up to 12 hours. To cancel the timer programme, press the timer button (D) again. Light (H) stops flashing.

How to programme delayed shut down

- Delayed shut down can be programmed in any operating mode (air conditioning / fan/ dehumidifying).
- Press the timer button (D). The timer light "H" flashes.
- Use the + (E) or - (F) buttons to set the number of hours delay before the appliance goes off.

The time increases or decreases in steps of one hour.

The light (H) flashes until the appliance turns off as programmed. At the set time, the air conditioner shuts down and remains in standby. To cancel the timer programme, press the timer button (D) again.

Light (H) stops flashing.

MODELS WITH REMOTE CONTROL

- Point the remote control at the receiver on the air conditioner. The remote control must be no more than 16,4 ft (5 metres) away from the appliance (without obstacles between the remote control

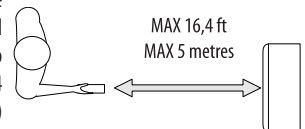

Using the remote control unit (some models only)

en

and the receiver).

- The remote control must be handled with extreme care. Do not drop it or expose it to direct sunlight or sources of heat.
- Replace the cover.

DESCRIPTION OF THE REMOTE CONTROL

- 19) "ON/OFF" button
- 20) Increase /Decrease button for temperature/programmed use
- 21) "MODE" button
- 22) "TIMER" button
- 23) °F/°C scale button
- 24) Fan speed selection button (MAX/MED/MIN).

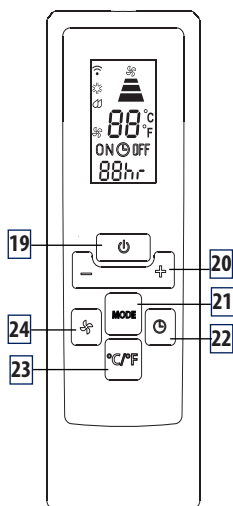

If the remote control unit is replaced or discarded, the batteries must be removed and disposed of in accordance with current legislation as they are harmful to the environment. Do not mix old and new batteries. Do not mix alkaline, standard (carbon-zinc) or rechargeable (nickel-cadmium) batteries. Do not dispose of batteries in fire. Batteries may explode or leak. If the remote control will not be used for a certain length of time, remove the batteries.

TURNING THE APPLIANCE ON

Plug the appliance into the mains.

Press the **ON/OFF** button (19) (when turned on, the air conditioner starts operating in the same mode as when it was turned off).

Press the **MODE** button (21) to select the required mode

COOLING

DEHUMIDIFYING

FAN ONLY

On the control panel, the light corresponding to the selected mode comes on.

For air conditioning/dehumidifying/fan only settings and programming the timer, see page 8.

Inserting or replacing the batteries

- Remove the cover on the rear of the remote control;
- Remove the old batteries, if present.
- Correctly insert two new L03 "AAA" 1,5V batteries (see the instructions inside the battery compartment);
- Replace the cover.

To get the best from your air conditioner, follow these recommendations:

- close the windows and doors in the room to be air conditioned.

The only exception is when the appliance is installed through a hole in the wall.

In this case, you are recommended to leave a slight draught through a door or window to guarantee correct ventilation.

- Protect the room from direct exposure to the sun by partially closing curtains and/or blinds to make the appliance much more economical to run;
- Never rest objects of any kind on the air conditioner;
- Never obstruct the air intake **6** or outlet **1** grilles;
- Make sure there are no heat sources in the room.

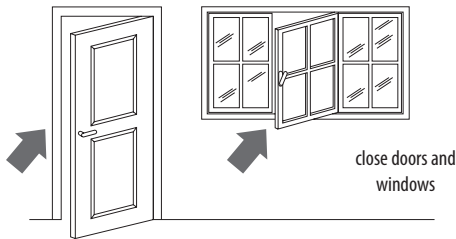

- Never use the appliance in very damp rooms (laundries for example).
- Never use the appliance outdoors.

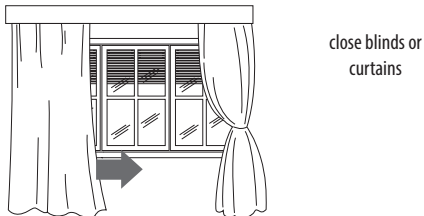

- Make sure the air conditioner is on a **level floor**.

Before cleaning or maintenance, turn the appliance off by pressing the ON/OFF button (A) or in models with remote control unit, by pressing the ON/OFF button 19 , then always unplug the appliance from the mains socket.

CLEANING THE CABINET

You should clean the appliance with a slightly damp cloth then dry with a dry cloth.

For safety reasons, never wash the air conditioner with water.

Precautions

Never use petrol, alcohol or solvents to clean the appliance. Never spray insecticide liquids or similar.

CLEANING THE AIR FILTERS

To keep your air conditioner working efficiently, you should clean the dust filter every week of operation.

The filter is housed in the intake grille.

To clean the filters, remove the filter as shown in figure L.

Use a vacuum cleaner to remove the dust collected on the filter.

If it is very dirty, immerse in warm water and rinse a number of times. The water should never be hotter than 40°C.

After washing, leave the filter to dry. Put the filter back in its housing.

START OF SEASON CHECKS

Make sure the power cable and plug are undamaged and the earth system is efficient. Follow the installation instructions precisely.

END OF SEASON OPERATIONS

To drain all water from the circuit, remove the external cap by unscrewing it in the anticlockwise direction then, remove the internal cap from the drain hose on the back of the appliance and allow the water to drain out into a basin (figure M). When the appliance is empty, replace the caps.

Clean the filter and dry thoroughly before putting back.

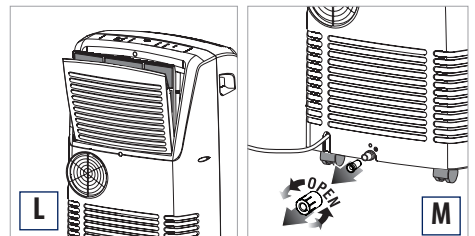



NOTE:

NEVER TRANSPORT OR TURN THE APPLIANCE UPSIDE DOWN OR ON ITS SIDE. IF THIS OCCURS, WAIT 6 HOURS BEFORE TURNING THE APPLIANCE ON, 24 HOURS IS RECOMMENDED. (After the unit has been on its side, oil needs to return to the compressor to ensure proper function. Without allowing the unit this time (6-24 hours) The unit may function for only a short time, and then the compressor will break down from lack of oil.)

PROBLEM	CAUSE	REMEDY
The air conditioning unit does not start.	<ul style="list-style-type: none"> No electricity. It is not plugged into the outlet. The safety device of the plug has tripped. 	<ul style="list-style-type: none"> Wait. Plug into the outlet. Reset the safety device, if problem persists contact our toll free customer service.
The air conditioning unit works for a short time only.	<ul style="list-style-type: none"> The air exhaust hose has a constriction. The air exhaust hose is blocked. There are tight bends in the air exhaust hose. 	<ul style="list-style-type: none"> Position the exhaust hose correctly. Check there are no obstacles. Obstructing air discharge. Eliminate the tight bends.
The air conditioner works, but does not cool the room.	<ul style="list-style-type: none"> Window open. The exhaust hose is detached. Air filters clogged. 	<ul style="list-style-type: none"> close the window. connect the exhaust hose. clean or replace the filter.
Particular odour in the room	<ul style="list-style-type: none"> air purifying filters clogged 	<ul style="list-style-type: none"> clean or replace the filters.
The air conditioner does not operate for about 3 minutes after turning it on	<ul style="list-style-type: none"> the safety device has tripped 	<ul style="list-style-type: none"> wait for three minutes.
The alarm light Q comes on	<ul style="list-style-type: none"> the tank inside the appliance is full. 	<ul style="list-style-type: none"> empty the tank (see “End of season operations) on page 10).

SELF-DIAGNOSIS

The appliance has a self diagnosis system to identify a number of malfunctions. Error messages are displayed on the appliance display.

IF...IS DISPLAYED,	IF...IS DISPLAYED,	IF...IS DISPLAYED,
 <p>“Low Temperature” ...MEANS: room temperature is too low</p>	 <p>“High Temperature” ...MEANS: room temperature is too high</p>	 <p>“Probe Failure” (sensor damaged) ...MEANS: contact your local customer service</p>

TECHNICAL SPECIFICATION

Power supply voltage	see rating label
Max. absorbed power during air conditioning	"
Refrigerant	"
Cooling capacity	"

LIMIT CONDITIONS

Room temperature for air conditioning	21 ÷ 35°C
---------------------------------------	-----------

Transport, filling, cleaning, recovery and disposal of refrigerant should be performed by a technical service centre appointed by the manufacturer only. The appliance should be disposed of by a specialist centre appointed by the manufacturer only.