

## CONTENTS

---

<b>1. FUNDAMENTAL SAFETY WARNINGS.....</b>	<b>89</b>
<b>2. SAFETY WARNINGS .....</b>	<b>90</b>
2.1 Symbols used in these instructions .....	90
2.2 Designated use.....	90
2.3 Instruction for Use.....	90
<b>3. INTRODUCTION.....</b>	<b>90</b>
3.1 Letters in brackets.....	90
3.2 Troubleshooting and repairs .....	90
<b>4. DESCRIPTION.....</b>	<b>91</b>
4.1 Description of the appliance .....	91
4.2 Description of the lights .....	91
4.3 Description of the control panel .....	91
4.4 Description of the accessories.....	91
4.5 Description of the milk container .....	91
<b>5. PRELIMINARY CHECKS.....</b>	<b>91</b>
5.1 Checking the appliance .....	91
5.2 Installing the appliance.....	91
<b>6. TURNING THE APPLIANCE ON.....</b>	<b>92</b>
<b>7. TURNING THE APPLIANCE OFF .....</b>	<b>92</b>
<b>8. SETTING WATER HARDNESS .....</b>	<b>92</b>
8.1 Measuring water hardness .....	92
8.2 Setting water hardness .....	93
8.3 Default values (reset) .....	93
<b>9. MAKING COFFEE.....</b>	<b>93</b>
9.1 Selecting the coffee taste.....	93
9.2 Selecting the coffee .....	93
9.3 Adjusting the coffee mill .....	93
9.4 Tips for a hotter coffee.....	94
9.5 Making coffee using coffee beans .....	94
9.6 Making coffee using pre-ground coffee.....	94
<b>10. MAKING DRINKS WITH MILK.....</b>	<b>94</b>
10.1 Filling and attaching the milk container.....	94
10.2 Adjusting the froth.....	95
10.3 Making drinks with milk automatically.....	95
10.4 Cleaning the milk container after use .....	95
<b>11. DELIVERING HOT WATER .....</b>	<b>95</b>
11.1 Delivering hot water .....	95
<b>12. PROGRAMMING THE QUANTITY THE CUP FOR ALL THE BEVERAGES.....</b>	<b>95</b>
<b>13. CLEANING.....</b>	<b>96</b>
13.1 Cleaning the machine's internal circuit.....	96
13.2 Cleaning the coffee grounds container.....	96
13.3 Cleaning the drip tray and condensate tray.....	96
13.4 Cleaning the inside of the coffee maker .....	96
13.5 Cleaning the water tank.....	96
13.6 Cleaning the coffee spouts .....	96
13.7 Cleaning the pre-ground coffee funnel .....	97
13.8 Cleaning the infuser .....	97
13.9 Cleaning the milk container .....	97
13.10 Cleaning the hot water/steam nozzle.....	97
<b>14. DESCAL.....</b>	<b>97</b>
<b>15. WATER SOFTENER FILTER (D4 - IF FITTED)..</b>	<b>98</b>
15.1 Installing the filter .....	98
<b>16. TECHNICAL SPECIFICATION .....</b>	<b>99</b>
<b>17. DISPOSAL.....</b>	<b>99</b>
<b>18. EXPLANATION OF LIGHTS.....</b>	<b>100</b>
<b>19. TROUBLESHOOTING .....</b>	<b>103</b>
<b>20. ELECTRICAL REQUIREMENTS (UK ONLY)...</b>	<b>104</b>

## 1. FUNDAMENTAL SAFETY WARNINGS

---

- The appliance is not intended for use by persons (including children) with reduced physical, sensory or mental capabilities, or lack of experience and knowledge, unless they have been given supervision or instruction concerning use of the appliance by a person responsible for their safety.
- Children should be supervised to ensure that they do not play with the appliance.
- Cleaning and user maintenance shall not be made by children without supervision.
- Never clean by immersing the appliance in water.
- This is an household appliance only. It is not intended to be used in: staff kitchen areas in shops, offices and other working environments; farm houses; by clients in hotels, motels and other residential type environments; bed and breakfast type environments.
- If the plug or cord is damaged, it must be replaced by Customer Services only to avoid all risk.

### FOR EUROPEAN MARKETS ONLY:

- This appliance can be used by children aged from 8 years and above if they have been given supervision or instruction concerning use of the appliance in a safe way and understand the hazards involved. Cleaning and user maintenance shall not be made by children unless they are older than 8 and supervised. Keep the appliance and power cord away from children under eight years of age.
- Appliances can be used by persons with reduced physical, sensory or mental capabilities or lack of experience and knowledge if they are supervised or have been given instruction concerning use of the appliance in a safe way and if they understand the hazards involved.
- Children shall not play with the appliance.
- Always unplug the appliance when left unattended and before assembly, taking apart or cleaning.



Surfaces marked with this symbol become hot during use (the symbol is present in certain models only).

## 2. SAFETY WARNINGS

### 2.1 Symbols used in these instructions

Important warnings are identified by these symbols. It is vital to respect these warnings.



Failure to observe the warning may result in life threatening injury by electric shock.



Failure to observe the warning could result in injury or damage to the appliance.



Failure to observe the warning could result in scalds or burns.



This symbol identifies important advice or information for the user.



This is an electrical appliance and may cause electric shock. You should therefore follow these safety warnings:

- Never touch the appliance with damp hands or feet.
- Never touch the plug with damp hands.
- Make sure the socket used is freely accessible at all times, enabling the appliance to be unplugged when necessary.
- Unplug directly from the plug only. Never pull the cord as you could damage it.
- To disconnect the appliance completely you must unplug it from the mains socket.
- If the appliance is faulty, do not attempt to repair. Turn it off, unplug from the mains socket and contact Customer Services.
- Before cleaning the appliance, turn it off, unplug from the mains socket and allow to cool.



Keep all packaging (plastic bags, polystyrene foam) away from children.



This appliance produces hot water and steam may form while it is in operation.

Avoid contact with splashes of water or hot steam.

When the appliance is in operation, the cup shelf could become very hot.

### 2.2 Designated use

This appliance is designed and made to prepare coffee and hot drinks.

Any other use is considered improper and thus dangerous. The manufacturer is not liable for damage deriving from improper use of the appliance.

### 2.3 Instruction for Use

Read this Instruction for Use carefully before using the appliance. Failure to follow this Instruction for Use may result in burns or damage to the appliance.

The manufacturer is not liable for damage deriving from failure to respect this Instruction for Use.



Keep this Instruction for Use. If the appliance is passed to other persons, they must also be provided with this Instruction for Use.

## 3. INTRODUCTION

Thank you for choosing this bean to cup espresso and cappuccino machine.

We hope you enjoy using your new appliance. Take a few minutes to read this Instruction for Use. This will avoid all risks and damage to the appliance.

### 3.1 Letters in brackets

The letters in brackets refer to the legend in the description of the appliance on page 2-3.

### 3.2 Troubleshooting and repairs

In the event of problems, first try and resolve them by reading the information given in the sections "18. EXPLANATION OF LIGHTS" and "19. TROUBLESHOOTING".

If this does not resolve the problem or you require further information, you should consult Customer Services by calling the number given on the annexed "Customer Service" sheet.

If your country is not among those listed on the sheet, call the number given in the guarantee. If repairs are required, contact De'Longhi Customer Services only. The addresses are given in the guarantee certificate provided with the machine.

## 4. DESCRIPTION

### 4.1 Description of the appliance

(page 3 - A )

- A1. Grinding adjustment dial
- A2. Beans container
- A3. Beans container lid
- A4. Pre-ground coffee funnel lid
- A5. Pre-ground coffee funnel
- A6. Cup shelf
- A7. Main switch
- A8. Infuser door
- A9. Infuser
- A10. Water tank lid
- A11. Water tank
- A12. Drip tray
- A13. Drip tray water level indicator
- A14. Cup tray
- A15. Coffee grounds container
- A16. Condensate tray
- A17. Coffee spout (adjustable height)
- A18. Hot water and steam nozzle
- A19. Socket for power cable connector

### 4.2 Description of the lights

(page 2 - B )

(for the meaning of the pilot lights, refer to "Explanation of lights")

- B1. : double size selected
- B2. : pre-ground coffee selected
- B3. : mild taste selected
- B4. : standard taste selected
- B5. : strong taste selected
- B6. : "Espresso" selected
- B7. : "Coffee" selected
- B8. : "Long" selected
- B9. : "Cappuccino" selected
- B10. : "Hot Milk" selected
- B11. : "Hot water" selected
- B12. : "See instruction booklet"
- B13. : Steady: "Empty grounds container"  
Blinking: "Insert grounds container"
- B14. : Steady: "Fill water tank"  
Blinking: "Insert water tank"
- B15. : "Descaling is required"
- B16. : "Insert milk jug"
- B17. : "Clean the milk frother"
- B18. : "Please wait"
- B19. : "Fill beans container"
- B20. : "General alarm"
- B21. : "Exit the menu"
- B22. : "Confirm"

### 4.3 Description of the control panel

(page 2 - C )

- C1. button: turns the appliance on and off (standby)
- C2. button: to select the coffee taste
- C3. button: to perform a rinse
- C4. button: to select double size (Espresso and coffee only)
- C5. button: to start descaling
- C6. button: to start delivery
- C7. "Select drink" knob

### 4.4 Description of the accessories

(page 2 - E )

- D1. "Total Hardness Test" indicator paper
- D2. Pre-ground coffee measure
- D3. Descaler
- D4. Water softener filter (\*certain models only)
- D5. Cleaning brush
- D6. Hot water spout
- D7. Removable power cord

### 4.5 Description of the milk container

(page 2 - E )

- E1. Froth and CLEAN dial
- E2. Milk container lid
- E3. Milk container
- E4. Milk intake tube
- E5. Frothed milk spout (adjustable)

## 5. PRELIMINARY CHECKS

### 5.1 Checking the appliance

After removing the packaging, make sure the product is complete and undamaged and that all accessories are present.

Do not use the appliance if it is visibly damaged.

Contact De'Longhi Customer Experience.

### 5.2 Installing the appliance

#### Important!

When installing the appliance, respect the following safety warnings:

- The appliance gives off heat.  
After positioning the appliance on the worktop, leave a space of at least 3 cm between the surfaces of the appliance and the side and rear walls and at least 15 cm above the coffee maker.
- Water penetrating the coffee maker could cause damage.  
Do not place the appliance near taps or sinks.
- The appliance could be damaged if the water it contains freezes.

Do not install the appliance in a room where the temperature could drop below freezing point.

- Arrange the power cable (D7) in such a way that it cannot be damaged by sharp edges or contact with hot surfaces (e.g. electric hot plates).

## Connecting the appliance



### **Important!**

Check that the mains power supply voltage corresponds to the value indicated on the rating plate on the bottom of the appliance.

If the power socket does not match the plug on the appliance, have the socket replaced with a suitable type by a qualified professional.

## Using the appliance for the first time





### **Please note!**

- Coffee has been used to factory test the appliance and it is therefore completely normal for there to be traces of coffee in the mill.

The machine is, however, guaranteed to be new.

- You should customise water hardness as soon as possible following the instructions in the section “8. SETTING WATER HARDNESS”.

Follow the instructions:

1. Remove the water tank (A11), fill to the MAX line with fresh water (fig. 1A) then put back in the appliance (fig. 1B).
2. Check that the hot water spout (D6) is inserted on the nozzle (A18) and place a container (fig. 2) with a minimum capacity of 100 ml underneath.
3. Plug the power cable connector into the socket at the back of the appliance (A19) and connect the appliance to the mains electricity supply. Press the main switch (A7 - fig. 3).
4. The  (B11) and the  (B22) lights turn on (fig. 4).
5. Press the  (C6): the appliance delivers water from the hot water spout then goes off.
6. The appliance automatically switches off.

The coffee maker is now ready for normal use.



### **Please note!**

- When using the appliance for the first time, you need to make 4-5 cups of coffee or 4-5 cappuccinos before the appliance starts to give satisfactory results.
- To enjoy your coffee even more and improve the performance of your appliance, we recommend installing a water softener filter (D4) as described in the section “15. WATER SOFTENER FILTER (D4 - if fitted)”. If your model is not provided with a filter, you can request one from De'Longhi Customer Services.

## 6. TURNING THE APPLIANCE ON



### **Please note!**

Before turning the appliance on, make sure the main switch (A7) is pressed (fig. 3).

Each time the appliance is turned on, it performs an automatic preheat and rinse cycle which cannot be interrupted.



The appliance is ready for use only after completion of this cycle.



### **Danger of burns!**

During rinsing, a little hot water comes out of the coffee spouts (A17) and is collected in the drip tray (A12) underneath.

Avoid contact with splashes of water.

- To turn the appliance on, press the  button (C1) (fig. 5).  (B18) flashes to indicate that the appliance is heating up and performing an automatic rinse cycle (by circulating hot water, the appliance heats both the boiler and the internal circuits).

The appliance is at temperature when the  light goes off and the lights corresponding to the coffee taste and beverages come on.

## 7. TURNING THE APPLIANCE OFF

Whenever the coffee machine is turned off after being used to make coffee, it performs an automatic rinse cycle.



### **Danger of burns!**

During rinsing, a little hot water flows from the coffee spouts (A17).

Avoid contact with splashes of water.

To turn the appliance off (standby), press the  button (C1) (fig. 5). The appliance performs a rinse cycle, then goes off.



### **Please note!**

If the appliance is not used for an extended period, switch off the machine at the main switch (A7 - fig. 3).

- first turn the appliance off by pressing the  button;
- release the main switch at the side of the appliance.



### **Important!**

Never press the main switch while the appliance is on.

## 8. SETTING WATER HARDNESS

The  (descaling) light (B15) turns on after a period of time according to water hardness.

The machine is factory set for a hardness value of 4.





The machine can also be programmed according to the hardness of the mains water in the various regions so that the machine needs to be descaled less often.









### 8.1 Measuring water hardness





1. Remove the “total hardness test” (D1) indicator paper attached to this manual from its pack.

- Immerse the paper completely in a glass of water for one second.
- Remove the paper from the water and shake lightly. After about a minute, 1, 2, 3, or 4 red squares form, depending on the hardness of the water. Each square corresponds to one level.

## 8.2 Setting water hardness

- With the machine on, keep pressed the  button (C3) for about six seconds until  (B15) lights on:  (B22) and  (B21) flash.
- Turn the knob (C7) until the required level is selected:

Turn knob	Select level	Corresponding water hardness test
	Soft water 	
	Slightly hard water 	
	Hard water 	
	Very hard water 	

- Press the  button (C6) to confirm: the  light (B18) turns on to indicate that the appliance is saving the new setting. (If you want to abort the new setting, press the  button, corresponding to .

The machine is now reprogrammed with the new water hardness setting.



## 8.3 Default values (reset)

This resets the water hardness level back to the default values.

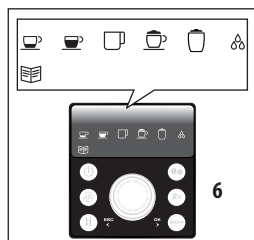

To reset the default values, proceed as follows:

- With the machine on, keep pressed the  button (C3) for about six seconds.

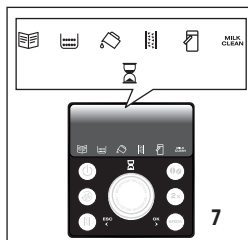

- Press again  button until the lights shown in fig. 6 come on:  (B22) and  (B21) flash.



- Press the  button (C6) to confirm: the lights shown in fig. 7 flash to indicate that the appliance is resetting the default values. (If you want to abort the operation, press the  button (C5), corresponding to .

## 9. MAKING COFFEE

### 9.1 Selecting the coffee taste

The appliance is set by default to make coffee with a standard taste.



You can also choose one of these tastes:

		
Mild taste	Standard taste	Strong taste

To change the taste, press the  button (C2 - fig. 8) repeatedly until the required taste is displayed.

### 9.2 Selecting the coffee

To select the coffee, turn the selection knob (C7 - fig. 9) until the light corresponding to the required quantity of coffee comes on:

Coffee selected	Quantity in cup (ml)	2-cups or double size
 ESPRESSO	40ml	Press
 COFFEE	120ml	<b>2x</b>
 LONG	120ml	--

If you want to deliver 2 cups of coffee or a double size of coffee, press the  button (C4): the corresponding light comes on.

### 9.3 Adjusting the coffee mill

The coffee mill is preset in the factory to make coffee correctly and should not require adjusting initially.

However, if after making the first few coffees you find that the coffee is too thin and not creamy enough or that delivery is too slow (a drop at a time), this can be corrected by adjusting the grinding adjustment dial (A1) (fig. 10).

 **Please note!**

The grinding adjustment dial must only be turned when the coffee mill is in operation.

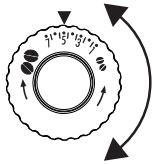

If the coffee is delivered too slowly or not at all, turn one click clockwise towards “7”.

For fuller bodied creamier coffee on the other hand, turn one click anticlockwise towards “1” (do not turn more than one click at a time otherwise the coffee could

be delivered a drop at a time).

These adjustments will only be evident after at least 2 cups of coffee have been delivered.

If this adjustment does not obtain the desired result, turn the dial another click.

#### 9.4 Tips for a hotter coffee

For a hotter coffee, before delivery you are recommended to:

- rinse the appliance through by pressing the button (C3). Hot water flows out of the coffee spouts (A17) and hot water spout (if inserted) heats the internal circuit of the machine so that the coffee delivered will be hotter.



**Danger of burns!** If inserted, hot water will flow out also from the hot water spout.

- warm the cups with hot water (using the hot water function).

#### 9.5 Making coffee using coffee beans



Do not use caramelised or candied coffee beans as they could stick to the coffee mill and make it unusable.

1. Place coffee beans in the coffee bean container (A2) (fig. 11).
2. Place under the coffee dispensing spouts (A17), either:
  - 1 cup if you want one coffee (fig. 12);
  - 2 cups if you want 2 coffees.
3. Lower the spouts as near as possible to the cup. This makes a creamier coffee (fig. 13).
4. Press the **BREW** button (C6).
5. Preparation begins and automatically stops.



**Please note:**

- While the machine is making coffee, delivery can be interrupted at any moment by pressing the **BREW** button.
- At the end of delivery, to increase the quantity of coffee in the cup, just press and hold (within 3 seconds) the **BREW** button.

Once the coffee has been made, the appliance is ready to make the next drink.



**Please note!**

- Lights may be displayed on the control panel (B) during use.

Their meaning is given in the section “18. EXPLANATION OF LIGHTS”.

- For hotter coffee, see the section “9.4 Tips for a hotter coffee”.
- If the coffee is delivered a drop at a time, too weak and not creamy enough or too cold, read the tips in the section “19. TROUBLESHOOTING”.

#### 9.6 Making coffee using pre-ground coffee



**Important!**

- Never add pre-ground coffee when the machine is off or it could spread through the inside of the machine and dirty it. This could damage the appliance.
- Never use more than 1 level measure or it could dirty the inside of the coffee maker or block the funnel.



**Please note!**

If you use pre-ground coffee, you can only make one cup of coffee at a time (it is suggested not to require double size).

1. Keep pressed the button (C2 - fig. 8) until (B2) is displayed.
2. Open the pre-ground coffee funnel lid (A4).
3. Make sure the funnel (A5) is not blocked, then add one level measure (D2) of pre-ground coffee (fig. 14).
4. Place a cup under the coffee spouts (A17) (fig. 12).

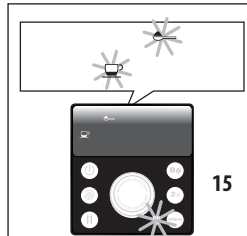

5. Press the **BREW** button (C6): the lights shown on fig. 15 come on.

6. Press the **BREW** button to confirm: preparation begins and automatically stops.

#### 10. MAKING DRINKS WITH MILK



**Please note!**

- To avoid producing milk with poor froth or large bubbles, always clean the milk container lid (E2) as described in the sections “10.4 Cleaning the milk container after use” and “13.9 Cleaning the milk container”.

##### 10.1 Filling and attaching the milk container

1. Remove the lid (E2) (fig. 16);
2. Fill the milk container (E3) with a sufficient quantity of milk, not exceeding the MAX level marked on the container (fig. 17). Each mark on the side of the container corresponds to 100 ml of milk.



**Please note!**

For a denser more even froth, you should use skimmed or partially skimmed milk at refrigerator temperature (about 5°C).

3. Make sure the milk intake tube (E4) is correctly inserted in the bottom of the milk container lid (fig. 18).
4. Place the lid back on the milk container.
5. Remove the hot water spout (C6) from the nozzle (A18).
6. Attach the container (E) to the nozzle and push as far as it will go (fig. 19).
7. Place a sufficiently large cup under the coffee (A17) and frothed milk spouts (E5). Adjust the length of the milk spout. To move it nearer the cup, simply pull it downwards (fig. 20).
8. Follow the instructions below for each function.



## 10.2 Adjusting the froth

Check that the froth adjustment dial on the milk container lid is on .

## 10.3 Making drinks with milk automatically

CAPPUCCINO and HOT MILK can be prepared automatically.

Proceed as follows:

1. Fill the milk container (E) and attach it as described above.
2. Turn the selection knob (C7 - fig. 9) until the light corresponding to the required milk beverage comes on:  
: "Cappuccino" (B9);  
: "Hot Milk" (B10).
3. Press the **BREW** button (C6).
4. After a few seconds, frothed milk is delivered from the milk spout (E5) into the cup below. The machine automatically makes the coffee after delivering the milk.

### **Please note!**

- If during delivery you want to stop preparation, press the **BREW** button.
- At the end of delivery, to increase the quantity of milk or coffee in the cup, just press and hold (within 3 seconds) the **BREW** button.
- Do not leave the milk container out of the refrigerator for long periods. The warmer the milk (5°C is ideal), the poorer the quality of froth produced.

## 10.4 Cleaning the milk container after use

### **Important! Danger of burns**

When cleaning the internal tubes of the milk container (E), a little hot water and steam leak out of the frothed milk spout (E5). Avoid contact with splashes of water.

MILK CLEAN lights (B17) on the display (B) each time you use a milk function. To eliminate all milk residues, proceed as follows:

1. Leave the milk container in the machine (you do not need to empty it);
2. Place a cup or other recipient under the frothed milk spout.
3. Turn the froth adjustment dial to "CLEAN" (E1 - fig. 21).
4. Cleaning starts and stops automatically.
5. Turn the dial back on .
6. Remove the milk container and always clean the steam connection nozzle (A18) with a sponge (see fig. 22).

### **Please note!**

- To prepare a number of milk based coffees, clean the milk container after you have prepared the last drink only.
- The milk container can be kept in the refrigerator.

## 11. DELIVERING HOT WATER

### **Important! Danger of burns.**

Never leave the machine unsupervised while delivering hot water.

The spout becomes hot during delivery. Hold by the handle only.

### 11.1 Delivering hot water

1. Make sure the hot water spout (D6) is attached correctly (fig. 2).
2. Place a container under the spout (as close as possible to avoid splashes).
3. Turn the selection knob (C7 - fig. 9) until the  light (B11) comes on.
4. Press the **BREW** button (C6).
5. The machine delivers hot water, then stops automatically. To interrupt delivery of hot water manually, press the **BREW** button again.

## 12. PROGRAMMING THE QUANTITY THE CUP FOR ALL THE BEVERAGES

The appliance is set by default to automatically deliver standard quantities. To change these quantities, proceed as follows:

1. Place a cup on the drip tray: the cup must be suitable for the beverage you want to customise.
2. Turn the selection knob (C7 - fig. 9) until the light corresponding to the required beverage comes on.
3. Press and hold the **BREW** button (C6): preparation starts
4. As soon as the light corresponding to the selected beverage flashes rapidly, release the **BREW** button.
5. Once the required quantity has been delivered into the cup, press the **BREW** button again. Delivery stops.

The machine is now reprogrammed with the new milk and coffee quantities.





### **Please note!**

- When programming milk beverages, both milk and coffee can be customised;
- When the beverage is ready, the light flashes for a few seconds indicating that the appliance is saving the new settings. Then the appliance is ready to use.

## **13. CLEANING**



### **Important!**

- Do not use solvents, abrasive detergents or alcohol to clean the coffee maker. With De'Longhi bean to cup coffee makers, you need not use chemical products to clean the machine.
- None of the components can be washed in a dishwasher apart from the milk container (E).
- Do not use metal objects to remove encrustations or coffee deposits as they could scratch metal or plastic surfaces.

### **13.1 Cleaning the machine's internal circuit**

If the appliance is not used for more than 3-4 days, before using it again, we strongly recommend switching it on and performing:

- 2/3 rinse cycles by pressing the button (C3);
- delivering hot water (see "11.1 Delivering hot water").



### **Please note:**

- After cleaning, it is normal for the grounds container (A15) to contain water.

### **13.2 Cleaning the coffee grounds container**

When (B13) comes on, the grounds container must be emptied and cleaned.

Until the grounds container has been cleaned, the appliance continues to display the message and coffee cannot be made.



### **Important! Danger of burns**

If you make a number of cappuccinos one after the other, the metal cup tray (A14) becomes hot.

Wait for it to cool down before touching it and handle it from the front only.

To clean (with the machine on):

- Remove the drip tray (A12) (fig. 23), empty and clean.
- Empty the grounds container and clean thoroughly to remove all residues left on the bottom. This can be done with the spatula on the brush (D5) provided.
- Check the condensate tray (A16) (red) and empty if necessary.



### **Important!**

When removing the drip tray, the grounds container must be emptied, even if it contains few grounds.

If this is not done, when you make the next coffees, the grounds container may fill up more than expected and clog the machine.

### **13.3 Cleaning the drip tray and condensate tray**



#### **Important!**

The drip tray (A12) is fitted with a level indicator (A13) (red) showing the level of water it contains (fig. 24).

Before the indicator protrudes from the cup tray (A14), the drip tray must be emptied and cleaned, otherwise the water may overflow the edge and damage the appliance, the surface it rests on or the surrounding area.

To remove the drip tray:

1. Remove the drip tray and the grounds container (A15) (fig. 23);
2. Empty the drip tray and grounds container and wash them;
3. Check the red condensate tray (A16) and empty if necessary.
4. Replace the drip tray and grounds container.

### **13.4 Cleaning the inside of the coffee maker**



#### **Danger of electric shock!**

Before cleaning internal parts, the machine must be turned off (see "7. TURNING THE APPLIANCE OFF") and unplugged from the mains power supply.

Never immerse the coffee maker in water.

1. Check regularly (about once a month) that the inside of the appliance (accessible after removing the drip tray - A12) is not dirty. If necessary, remove coffee deposits with the brush (D5) provided or a sponge.
2. Remove the residues with a vacuum cleaner (fig. 25).

### **13.5 Cleaning the water tank**

1. Clean the water tank (A11) regularly (about once a month) and whenever you replace the water softener filter (D4) (if provided) with a damp cloth and a little mild washing up liquid.
2. Remove the filter (if present) and rinse with running water.
3. Replace the filter (if provided), fill the tank with fresh water and replace the tank.

### **13.6 Cleaning the coffee spouts**

1. Regularly clean the coffee spouts (A17) with a sponge or cloth (fig. 26A).
2. Check the holes in the coffee spout are not blocked. If necessary, remove coffee deposits with a toothpick (fig. 26B).

### 13.7 Cleaning the pre-ground coffee funnel

Check regularly (about once a month) that the pre-ground coffee funnel (A5) is not blocked. If necessary, remove coffee deposits with the brush (D5) supplied.

### 13.8 Cleaning the infuser

The infuser (A9) must be cleaned at least once a month.

#### **Important!**

The infuser may not be extracted when the machine is on.

1. Make sure the machine is correctly turned off (see "7. TURNING THE APPLIANCE OFF").
2. Remove the water tank (A11).
3. Open the infuser door (A8-fig. 27) on the right side.
4. Press the two coloured release buttons inwards and at the same time pull the infuser outwards (fig. 28).
5. Soak the infuser in water for about 5 minutes, then rinse under the tap.

#### **Important!**

RINSE WITH WATER ONLY

NO WASHING UP LIQUID - NO DISH WASHER

Clean the infuser without using washing up liquid as it could be damaged.

6. Use the brush (D5) to remove any coffee residues left in the infuser housing, visible through the infuser door.
7. After cleaning, replace the infuser by sliding it onto the internal support; then push the PUSH symbol fully in until it clicks into place (fig. 29).

#### **Please note!**

If the infuser is difficult to insert, before insertion, adapt it to the right size by pressing the two levers shown in fig. 30 .

8. Once inserted, make sure the two coloured buttons have snapped out (fig. 31).
9. Close the infuser door.
10. Replace the water tank.

### 13.9 Cleaning the milk container

Clean the milk container (E) every two days as described below:

1. Remove the lid (E2).
2. Remove the milk spout (E5) and intake tube (E4).
3. Turn the froth adjustment dial (E1) clockwise to the "INSERT" position (fig. 32) and pull off upwards.
4. Wash all the components thoroughly with hot water and mild washing-up liquid. All components are dishwasher safe, placing them in the top basket of the dishwasher. Make sure there are no milk residues on the hollow and groove under the dial (see fig. 33). If necessary, scrape the groove with a toothpick.

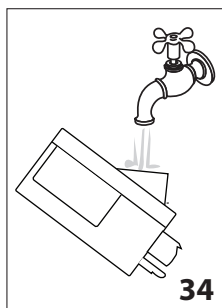

5. Rinse inside the froth adjustment dial seat with running water (fig. 34).
6. Check that the intake tube and spout are not clogged with milk residues.
7. Replace the dial (in correspondence to the word "INSERT"), spout and milk intake tube.
8. Place the lid back on the milk container.

### 13.10 Cleaning the hot water/steam nozzle

Each time you prepare milk, clean the nozzle (A18) with a sponge to remove milk residues from the gaskets (see fig. 22).





## 14. DESCAL

Descal the machine when  (B15) appears on the display (B).

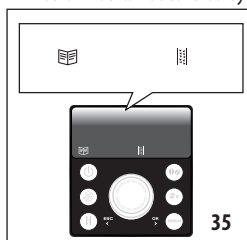
#### **Important!**

- Before use, read the instructions and the labelling on the descaler pack.
- You should use De'Longhi descaler only. Using unsuitable descaler and/or performing descaling incorrectly may result in faults not covered by the manufacturer's guarantee.



1. Turn the machine on and wait until the appliance is ready for use.
2. Press the  (C5) button: the lights shown in fig. 35 come on:  (B22) and  (B21) flash.
3. Press the **BREW** button (C6) to confirm. (If you want to abort the operation, press the  button, corresponding to ).
4. Empty the water tank (A11) and remove the softener filter (D4), if present.

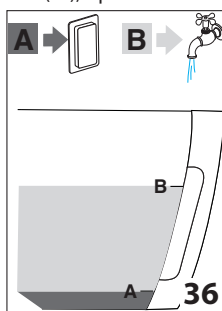

5. Pour the descaler (D3) into the tank up to the level A (corresponding to a 100ml pack) marked on the back of the tank (fig. 36A), then add water (1liter) up to level B (fig. 36B). Reinsert the water tank. Place an empty container with a minimum capacity of 1.8 l under the coffee

spout (A17) and hot water spout (D6).













### **Important! Danger of burns**

Hot water containing acid flows from the coffee and hot water spouts. Avoid contact with splashes of this solution.

6. Press the **BREW** button to confirm that you have added the descaling solution.

The descale programme automatically performs a series of rinses and pauses to remove limescale deposits from inside the machine. The descale programme starts and the descaler liquid comes out of coffee and hot water spouts.

After about 25 minutes, descaling stops and the  (B17),  (B16) and  (B14) lights come on.

7. The appliance is now ready for rinsing through with clean water. Extract the water tank, empty, rinse under running water, fill with clean water up to the MAX level, and put the water tank back in the machine. The  light comes on.
8. Empty the container used to collect the descaler solution and replace it empty under the coffee and water spouts.
9. Press the  button to start the first rinsing. Hot water flows out of the coffee and hot water spouts.
10. When the water tank is completely empty, the  and  lights come on.
11. Extract the water tank, empty, rinse under running water, fill with clean water up to the MAX level, insert the filter (if removed previously) and put the water tank back in the machine. The  light comes on.
12. Press the  button to start the second rinsing. Hot water flows out of the hot water spout only.
13. At the end of the rinse, the  light comes on. Press  and fill the water tank: the appliance is ready for use.



### **Please note!**

- If the descaling cycle is not completed correctly (e.g. lack of electricity) we recommend repeating the cycle.
- After descaling, it is normal for the grounds container (A15) to contain water.

## **15. WATER SOFTENER FILTER (D4 - IF FITTED)**

Certain models are fitted with a water softener filter. If this is not the case with your model, you are recommended to purchase one from De'Longhi Customer Services.

To use the filter correctly, follow the instructions below.

## **15.1 Installing the filter**

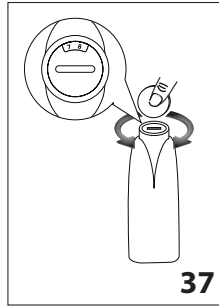

**37**

1. Remove the filter (D4) from the packaging.
2. Turn the date indicator disk (fig. 37) until the next two months of use are displayed.



### **Please note**

The filter lasts about two months if the appliance is used normally. If the coffee machine is left unused with the filter installed, it will last a maximum of three weeks.

3. To activate the filter, run tap water through the hole in the filter as shown in the figure until water comes out of the openings at the side for more than a minute (fig. 38).

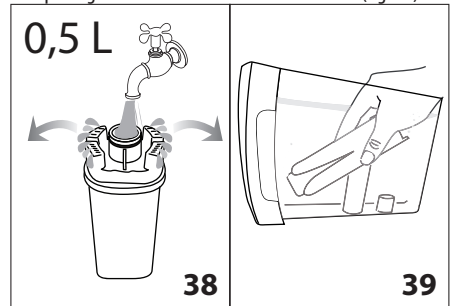

**38**

**39**

4. Extract the tank (A11) from the appliance and fill with water.
5. Insert the filter in the water tank and immerse it completely for about ten minutes, sloping it to enable the air bubbles to escape (fig. 39).
6. Insert the filter in the filter housing and press as far as it will go (fig. 40A)
7. Close the tank with the lid (A10), then put the tank back in the machine (fig. 40B).

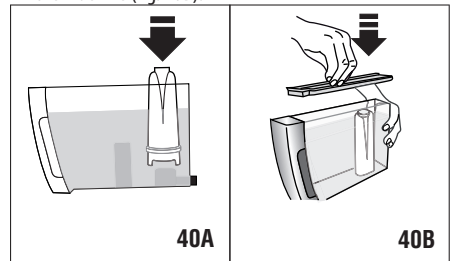

**40A**

**40B**

8. Place a container under the water spout (min. capacity: 500ml);
9. Deliver at least 500 ml of water (see "11.1 Delivering hot water").

 **Important!**

After two months (see date indicator) or when the appliance has not been used for 3 weeks, you should replace the filter with a new one, repeating the procedure for the installation.

## 16. TECHNICAL SPECIFICATION

---

Voltage:	see rating label
Absorbed power:	see rating label
Pressure:	1,5 MPa (15 bar)
Water tank capacity:	1,8 l
Size Lxdxh:	240x430x350 mm
Cable length:	1750 mm
Weight:	9,7 kg
Beans container capacity:	250 g max.

 The appliance complies with the following EC directives:

- European Standby Regulation 1275/2008
- Materials and accessories coming into contact with food conform to EEC regulation 1935/2004.



















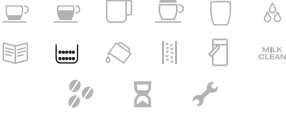



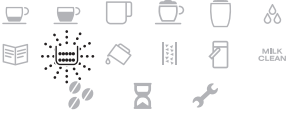



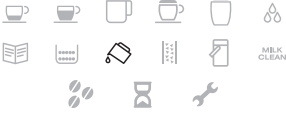



## 17. DISPOSAL







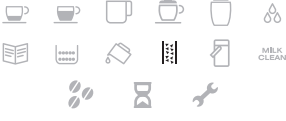

---









The appliance must not be disposed of with household waste, but taken to an authorised waste separation and recycling centre.

## 18. EXPLANATION OF LIGHTS

LIGHT	POSSIBLE CAUSE	REMEDY
<p>2x    </p> 	The appliance is heating up	Wait
<p>2x    </p> 	The grounds container (A15) is full	Empty the grounds container and drip tray (A12), clean and replace. Important: when removing the drip tray, the grounds container MUST be emptied, even if it contains few grounds. If this is not done, when you make the next coffees, the grounds container may fill up more than expected and clog the machine
<p>2x    </p> 	After cleaning, the grounds container has not been replaced (A15)	Remove the drip tray (A12) and insert the grounds container
	The grounds container is not correctly inserted	Check that the grounds container is correctly inserted
<p>2x    </p> 	Insufficient water in the tank (A11)	Fill the tank with water and/or insert it correctly, pushing it as far as it will go until it clicks into place
<p>2x    </p> 	The water tank is not inserted (A11)	Insert the water tank
<p>2x    </p> 	The coffee beans have run out	Fill the beans container (A2)
<p>2x    </p> 	The machine must be descaled.	The descaling procedure described in the section “Descaling” needs to be performed as soon as possible

<p>2x</p> 	<p>The milk container (E) is not inserted correctly or it is not inserted at all</p>	<p>Insert the milk container as far as it will go</p>
<p>2x</p> 	<p>Milk has been delivered recently and the tubes inside the milk container (E) must be cleaned</p>	<p>Turn the froth adjustment dial (E1) to CLEAN (fig. 21)</p>
<p>2x</p> 	<p>The milk frother knob (E1) is on wrong position after CLEAN</p>	<p>Turn the knob on  position</p>
<p>2x</p> 	<p>The water spout (D6) is not inserted or is inserted incorrectly</p>	<p>Insert the water spout as far as it will go</p>
<p>2x</p> 	<p>Water spout (D6) is required instead of milk container (E)</p>	<p>Insert water spout</p>
<p>2x</p> 	<p>General alarm</p>	<p>Contact a service center.</p>
<p>2x</p> 	<p>The infuser (A9) has not been replaced after cleaning</p>	<p>Insert the infuser as described in the section "13.8 Cleaning the infuser"</p>

	<p>The grinding is too fine and the coffee is delivered too slowly or not at all</p>	<p>Repeat coffee delivery and turn the grinding adjustment knob (A1) (fig. 10) one click clockwise towards "7" while the coffee mill is in operation.</p> <p>If after making at least 2 coffees delivery is still too slow, repeat the correction procedure, turning the grinding adjustment knob another click until delivery is correct (see the section "9.3 Adjusting the coffee mill").</p> <p>If the problem persist deliver hot water from the water spout.</p>
	<p>If the water softener filter (D4) is present, an air bubble may have been released inside the circuit, obstructing delivery.</p>	<p>Deliver a little water until the flow is regular (see "11.1 Delivering hot water").</p>
	<p>Pre-ground function was selected but no pre-ground coffee was poured</p>	<p>Pour pre-ground coffee in the coffee funnel (A5).</p>
	<p>Pre-ground coffee is blocked in the funnel</p>	<p>Clean the preground coffee funnel (see "13.7 Cleaning the pre-ground coffee funnel").</p>
	<p>Too much coffee has been used</p>	<p>Select a milder taste or reduce the quantity of pre-ground coffee then make the coffee again.</p>
	<p>The water circuit is empty: it is necessary to insert the water spout (D6).</p>	<p>Insert the water spout and deliver hot water</p>
	<p>The water circuit is empty.</p>	<p>Press OK (C6) to deliver water from the spout (D6) until it flows out normally. If the problem persists, make sure the water tank is fully inserted.</p>

## 19. TROUBLESHOOTING

Below is a list of some of the possible malfunctions.

If the problem cannot be resolved as described, contact Customer Services.

PROBLEM	POSSIBLE CAUSE	SOLUTION
The coffee is not hot	The cups were not preheated	Warm the cups by rinsing them with hot water (N.B. you can use the hot water function)
	The infuser (A9) has cooled down because 2/3 minutes have elapsed since the last coffee was made	Before making the coffee, warm the infuser by performing a rinse (see "9.4 Tips for a hotter coffee")
The coffee is thin or not creamy enough	The coffee is ground too coarsely	Turn the grinding adjustment dial (A1) one click anticlockwise towards "1" while the coffee mill is in operation (fig. 10). Continue one click at a time until coffee delivery is satisfactory. The effect is only visible after delivering 2 coffees (see the section "9.3 Adjusting the coffee mill")
	The coffee is unsuitable	Use pre-ground coffee for espresso coffee makers
The coffee is delivered too slowly or a drop at a time	The coffee is ground too finely	Turn the grinding adjustment dial (A1) one click clockwise towards "7" while the coffee mill is in operation (fig. 10). Continue one click at a time until coffee delivery is satisfactory. The effect is only visible after delivering two coffees. (see the section "9.3 Adjusting the coffee mill")
Coffee does not come out of one of the spouts	The spouts are blocked (A17).	Clean the spouts with a toothpick (fig. 26B)
The milk does not come out of the milk spout	The milk container lid (E2) is dirty.	Clean the milk container lid as described in the section "10.4 Cleaning the milk container after use"
The milk contains large bubbles and squirts out of the milk spout or there is little froth	The milk container lid is dirty (E2).	Clean the milk container lid as described in the section "10.4 Cleaning the milk container after use"
	The milk is not cold enough or is not semi-skimmed	Use skimmed or semi-skimmed milk at refrigerator temperature (about 5°C). If the result is not as you wished, try changing brand of milk
	The froth adjustment dial (E1) is incorrectly adjusted.	Adjust following the instructions in the section "10.2 Adjusting the froth"
	The milk container lid (E2) or froth adjustment dial is dirty (E1).	Clean the milk container lid and dial as described in the section "13.9 Cleaning the milk container"
The appliance does not come on	It is not plugged into the mains socket	Plug into the mains socket
	The main switch (A7) is not turned on	Push the main switch (fig. 3)
The infuser cannot be extracted	The appliance has not been turned off correctly	Turn the appliance off by pressing the  button (C1) (see "7. TURNING THE APPLIANCE OFF")



## 20. ELECTRICAL REQUIREMENTS (UK ONLY)

Before using this appliance ensure that the voltage indicated on the product corresponds with the main voltage in your home, if you are in any doubt about your supply contact your local electricity company.

The flexible mains lead is supplied connected to a B.S. 1363 fused plug having a fuse of 13 amp capacity.

Should this plug not fit the socket outlets in your home, it should be cut off and replaced with a suitable plug, following the procedure outlined below.

Note: Such a plug cannot be used for any other appliance and should therefore be properly disposed of and not left where children might find it and plug it into a supply socket - with the obvious consequent danger.

N.B. We recommend the use of good quality plugs and wall sockets that can be switched off when the machine is not in use.

IMPORTANT: the wires in the mains lead fitted to this appliance are coloured in accordance with the following code:

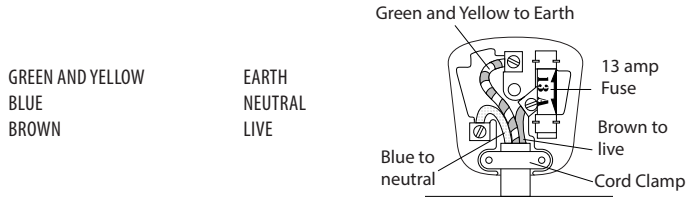

As the colours of the wires in the mains lead of this appliance may not correspond with the coloured markings identifying the terminals in your plug, proceed as follows:

- The wire which is coloured green and yellow must be connected to the terminal in the plug which is marked with the letter E or by the earth symbol  or coloured green or green and yellow.
- The wire which is coloured blue must be connected to the terminal which is marked with the letter N or coloured black.
- The wire which is coloured brown must be connected to the terminal which is marked with the letter L or coloured red.

When wiring the plug, ensure that all strands of wire are securely retained in each terminal. Do not forget to tighten the mains lead clamp on the plug. If your electricity supply point has only two pin socket outlets, or if you are in doubt, consult a qualified electrician.

Should the mains lead ever require replacement, it is essential that this operation be carried out by a qualified electrician and should only be replaced with a flexible cord of the same size.

After replacement of a fuse in the plug, the fuse cover must be refitted. If the fuse cover is lost, the plug must not be used until a replacement cover is obtained. The colour of the correct replacement fuse cover is that of the coloured insert in the base of the fuse recess or elsewhere on the plug. Always state this colour when ordering a replacement fuse cover.

Only 13amp replacement fuses which are approved to B.S. 1362 should be fitted.

This appliance conforms to the Norms EN 55014 regarding the suppression of radio interference.

Warning - this appliance must be earthed