

ESAM45XY

BEAN TO CUP ESPRESSO
AND CAPPUCCINO MACHINE
Instruction for Use

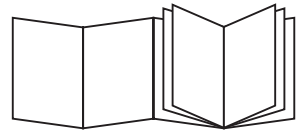

DeLonghi



ELECTRICAL CONNECTION (UK ONLY)

Before using this appliance ensure that the voltage indicated on the product corresponds with the main voltage in your home, if you are in any doubt about your supply contact your local electricity company.

The flexible mains lead is supplied connected to a B.S. 1363 fused plug having a fuse of 13 amp capacity.

Should this plug not fit the socket outlets in your home, it should be cut off and replaced with a suitable plug, following the procedure outlined below.

Note: Such a plug cannot be used for any other appliance and should therefore be properly disposed of and not left where children might find it and plug it into a supply socket - with the obvious consequent danger.

Please note: We recommend the use of good quality plugs and wall sockets that can be switched off when the machine is not in use.

IMPORTANT: The wires in the mains lead fitted to this appliance are coloured in accordance with the following code:

GREEN AND YELLOW
BLUE
BROWN

EARTH
NEUTRAL
LIVE

Green and Yellow to Earth

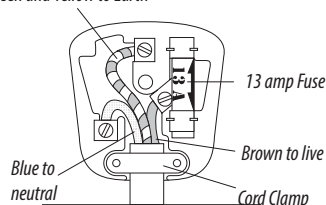

As the colours of the wires in the mains lead of this appliance may not correspond with the coloured markings identifying the terminals in your plug, proceed as follows:

- The wire which is coloured green and yellow must be connected to the terminal in the plug which is marked with the letter E or by the earth symbol  or coloured green or green and yellow.
- The wire which is coloured blue must be connected to the terminal which is marked with the letter N or coloured black.
- The wire which is coloured brown must be connected to the terminal which is marked with the letter L or coloured red.

When wiring the plug, ensure that all strands of wire are securely retained in each terminal. Do not forget to tighten the mains lead clamp on the plug. If your electricity supply point has only two pin socket outlets, or if you are in doubt, consult a qualified electrician.

Should the mains lead ever require replacement, it is essential that this operation be carried out by a qualified electrician and should only be replaced with a flexible cord of the same size.

After replacement of a fuse in the plug, the fuse cover must be refitted. If the fuse cover is lost, the plug must not be used until a replacement cover is obtained. The colour of the correct replacement fuse cover is that of the coloured insert in the base of the fuse recess or elsewhere on the plug. Always state this colour when ordering a replacement fuse cover.

Only 13amp replacement fuses which are asta approved to B.S. 1362 should be fitted.

This appliance conforms to the Norms EN 55014 regarding the suppression of radio interference.

Warning - this appliance must be earthed

A

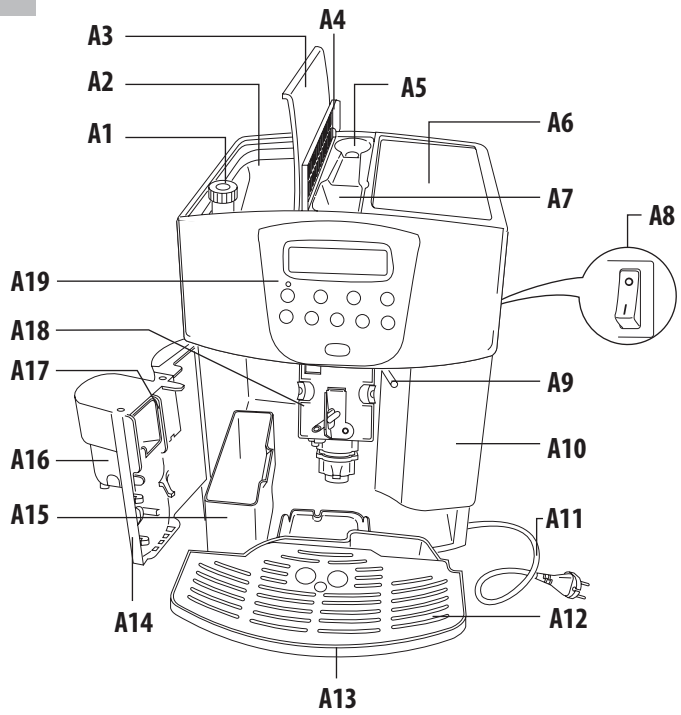

B

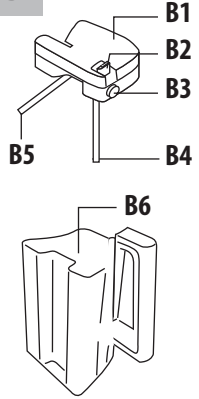

C

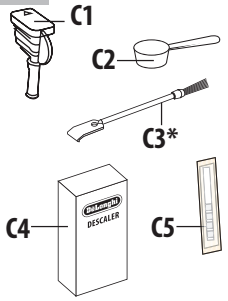

B

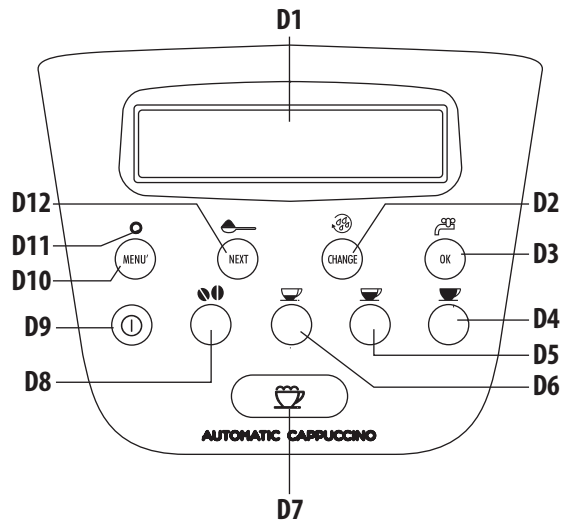

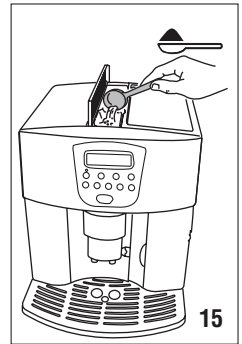
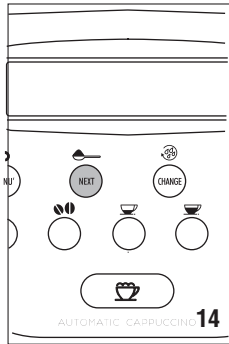
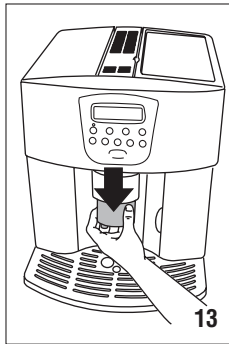
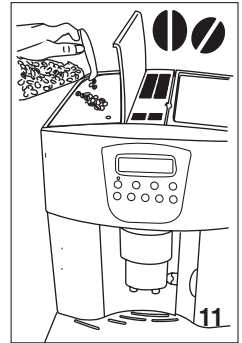
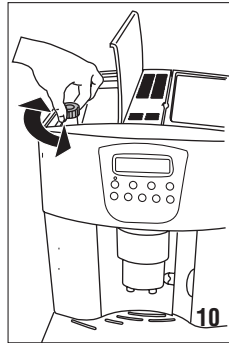
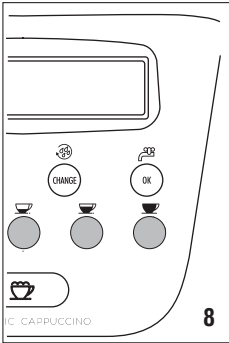
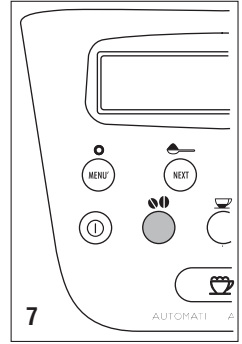
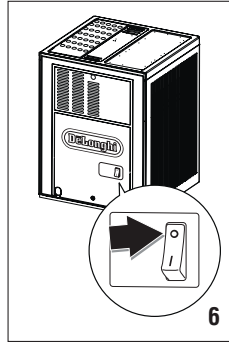
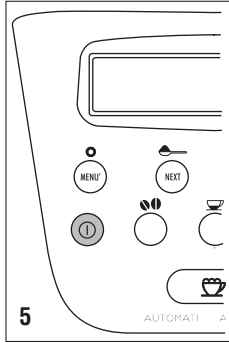
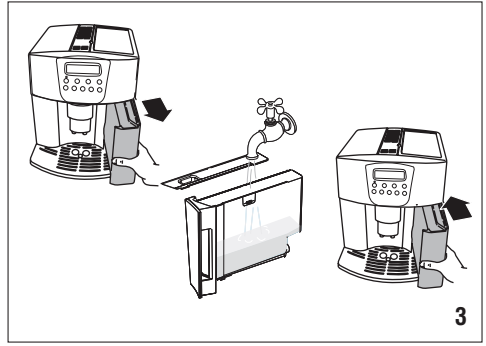
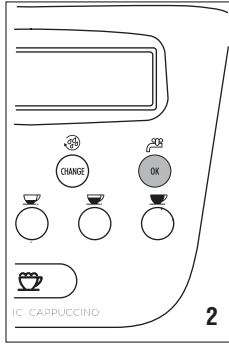
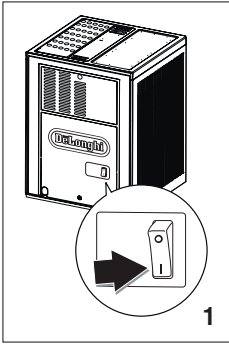

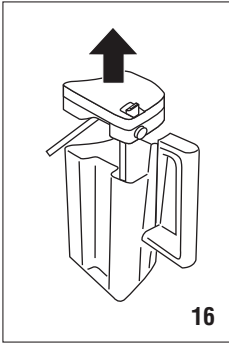

16

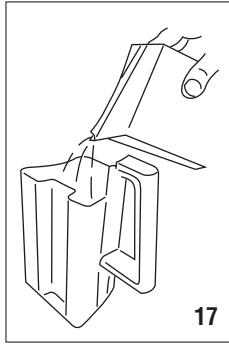

17

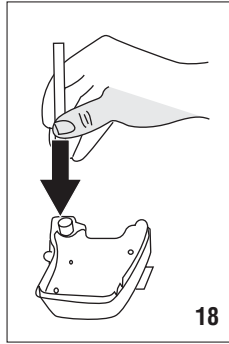

18

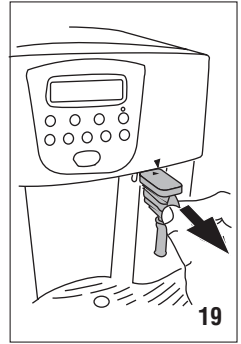

19



20

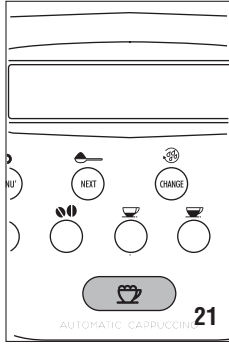

21

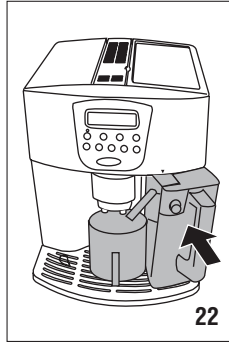

22

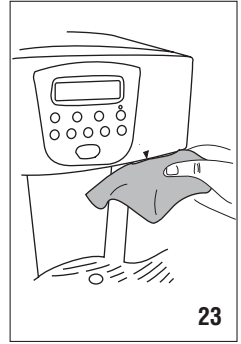

23



24

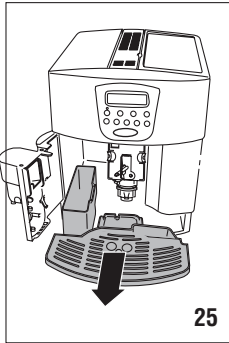

25

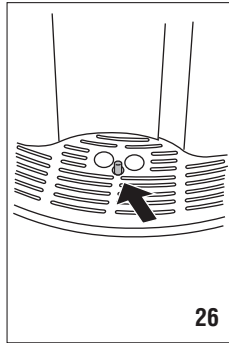

26

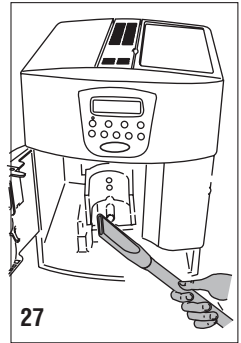

27

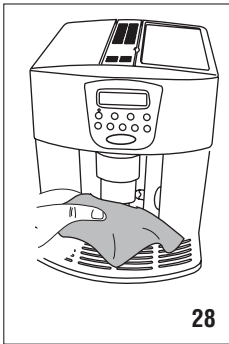

28

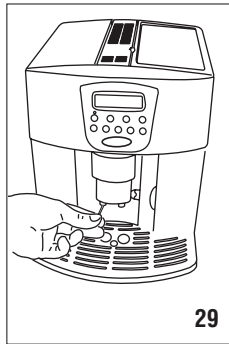

29

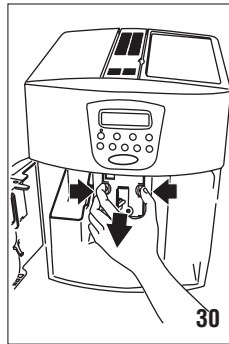

30

CONTENTS

ELECTRICAL REQUIREMENTS	2
INTRODUCTION	7
Symbols used in these instructions	7
Letters in brackets	7
Troubleshooting and repairs	7
SAFETY	7
Fundamental safety warnings	7
DESIGNATED USE	7
INSTRUCTIONS	8
DESCRIPTION	8
Description of the appliance	8
Description of milk container	8
Description of accessories	8
Description of control panel	8
PRELIMINARY CHECKS	8
Checking the appliance	8
Installing the appliance	8
Connecting the appliance	9
Using the appliance for the first time	9
TURNING THE APPLIANCE ON	9
TURNING THE APPLIANCE OFF	9
MENU SETTINGS	10
Clock	10
Turning on	10
Auto-start	10
Descaling	10
Temperature	10
Off after (Stand-by)	10
Water hardness	10
Default values (reset)	10
Setting the language	10
MAKING COFFEE	11
Selecting the coffee taste	11
Selecting the quantity of coffee in the cup	11
Programming quantity	11
Regulating the coffee mill	11
Manual rinsing	11
Tips for a hotter coffee	11
Preparing coffee using coffee beans	11
Making coffee using pre-ground coffee	12
MAKING DRINKS WITH MILK	12
Filling and attaching the milk container	12
Making cappuccino	12
Making frothed milk	12
Cleaning the milk container after use	12
Programming the quantities of coffee and milk in the cup	13
HEATING WATER	13
Preparation	13
Changing the quantity	13
CLEANING	13
Cleaning the coffee maker	13
Cleaning the coffee grounds container	13
Cleaning the drip tray	14
Cleaning the inside of the machine	14
Cleaning the water tank	14
Cleaning the coffee spouts	14
Cleaning the pre-ground coffee funnel	14
Cleaning the infuser	14
Cleaning the milk container	15
DESCALING	15
SETTING WATER HARDNESS	15
Measuring water hardness	15
DISPLAYED MESSAGES	16
Set water hardness	16
SET LANGUAGE	16
TECHNICAL SPECIFICATION	16
DISPOSAL	16
DISPLAYED MESSAGES	16
TROUBLESHOOTING	17

FUNDAMENTAL SAFETY WARNINGS

- The appliance is not intended for use by persons (including children) with reduced physical, sensory or mental capabilities, or lack of experience and knowledge, unless they have been given supervision or instruction concerning use of the appliance by a person responsible for their safety.
- Children should be supervised to ensure that they do not play with the appliance.
- Cleaning and user maintenance shall not be made by children without supervision.
- Never clean by immersing the appliance in water.
- This is an household appliance only. It is not intended to be used in: staff kitchen areas in shops, offices and other working environments; farm houses; by clients in hotels, motels and other residential type environments; bed and breakfast type environments.
- If the plug or power cable is damaged, it must be replaced by customer services only to avoid all risk.

FOR EUROPEAN MARKETS ONLY:

- This appliance can be used by children aged from 8 years and above if they have been given supervision or instruction concerning use of the appliance in a safe way and if they understand the hazard involved. Cleaning and user maintenance shall not be made by children unless they are older than 8 and supervised.
- Keep the appliance and its cord out of the reach of children aged less than 8 years
- Appliances can be used by persons with reduced physical, sensory or mental capabilities or lack of experience and knowledge if they have been given supervision or instruction concerning use of the appliance in a safe way and if they understand the hazards involved.
- Children shall not play with the appliance.
- When not in use and before putting on or taking off parts or cleaning, always unplug the appliance.



Surfaces marked with this symbol become hot during use (the symbol is present in certain models only).

IMPORTANT SAFEGUARDS

Symbols used in these instructions

Important warnings are identified by these symbols. It is vital to respect these warnings.



Danger!

Failure to observe the warning may result in life threatening injury by electric shock.



Important!

Failure to observe the warning could result in injury or damage to the appliance.



Danger of burns!

Failure to observe the warning could result in scalds or burns.



Please note:

This symbol identifies important advice or information for the user.



Danger!

This is an electrical appliance and may cause electric shock.

You should therefore follow these safety warnings:

- Never touch the appliance with damp hands or feet.
- Never touch the plug with damp hands.
- Make sure the socket used is freely accessible at all times, enabling the appliance to be unplugged when necessary.
- Unplug directly from the plug only. Never pull the cord as you could damage it.
- To disconnect the appliance completely you must unplug it from the mains socket.
- If the appliance is faulty, do not attempt to repair. Turn it off, unplug from the mains socket and contact Customer Services.
- Before cleaning the appliance, turn it off, unplug from the mains socket and allow to cool.



Important:

Keep all packaging (plastic bags, polystyrene foam) away from children.



Danger of burns!

This appliance produces hot water and steam may form while it is in operation.

Avoid contact with splashes of water or hot steam.

When the appliance is in operation, the cup shelf (A6) could become very hot.

Designated use

This appliance is designed and made to prepare coffee and heat drinks.

Any other use is considered improper and thus dangerous. The manufacturer is not liable for damage deriving from improper use of the appliance.

Instruction for Use

Read this Instruction for Use carefully before using the appliance. Failure to follow this Instruction for Use may result in burns or damage to the appliance.

The manufacturer is not liable for damage deriving from failure to respect this Instruction for Use.



Please note:

Keep this Instruction for Use. If the appliance is passed to other persons, they must also be provided with this Instruction for Use.

INTRODUCTION

Thank you for choosing this bean to cup espresso and cappuccino machine.

We hope you enjoy using your new appliance. Take a few minutes to read this Instruction for Use. This will avoid all risks and damage to the appliance.

Letters in brackets

The letters in brackets refer to the legend in the description of the appliance on page 2-3.

Troubleshooting and repairs

In the event of problems, first try and resolve them following the information given in the sections "Displayed messages" on page 20 and "Troubleshooting" on page pagina 22.

If this does not resolve the problem or you require further information, you should consult Customer Services by calling the number given on the annexed "Customer Service" sheet.

If your country is not among those listed on the sheet, call the number given in the guarantee. If repairs are required, contact De'Longhi Customer Services only. The addresses are given in the guarantee certificate provided with the machine.

DESCRIPTION

Description of the appliance

(page 3 - A)

- A1. Grinding adjustment knob
- A2. Beans container
- A3. Beans container lid
- A4. Central pre-ground coffee lid
- A5. Measure compartment
- A6. Cup warmer
- A7. Pre-ground coffee funnel
- A8. Main switch
- A9. Hot water spout
- A10. Water tank
- A11. Power cable
- A12. Cup tray
- A13. Drip tray
- A14. Service door
- A15. Grounds tray
- A16. Coffee spout (adjustable height)
- A17. Coffee guide
- A18. Infuser
- A19. Control panel

Description of milk container

(page 3 - B)

- B1. Lid with milk frother
- B2. CLEAN button
- B3. Milk intake tube
- B4. Frothed milk spout
- B5. Milk container

Description of accessories



(page 3 - C)







- C1. Hot water spout
- C2. Measure
- C3. Cleaning brush
- C4. Descaler
- C5. Total hardness test

Description of control panel

(page 3 - D)

A number of buttons on the panel have a double function. This is indicated in brackets in the description.

- D1. Display: guides the user in using the appliance.
- D2.  button: to perform a manual rinse cycle. *(When in the settings MENU: CHANGE button, press to modify the menu parameters).*
- D3.  button: to deliver hot water to make hot drinks. *(When in the settings MENU: OK button, press to confirm the selection made).*
- D4.  button: to deliver one or two cups of long coffee.

- D5.  button: to deliver one or two cups of standard coffee.
- D6.  button: to deliver one or two cups of short coffee.
- D7.  button: to deliver cappuccino or frothed milk (press button twice).
- D8.  button: to select the required aroma.
- D9.  button: to turn the appliance on and off (stand-by).
- D10. **MENU** button: to access the menu:
- D11. Menu light: comes on when you are in the settings menu.
- D12.  button: to select pre-ground coffee. *(When in the settings menu, NEXT button, press to display the next menu parameter).*

PRELIMINARY CHECKS

Checking the appliance

After removing the packaging, make sure the product is complete and undamaged and that all accessories are present. Do not use the appliance if it is visibly damaged. Contact De'Longhi Customer Services.

Installing the appliance



Important!

When you install the appliance, you should respect the following safety warnings:

- The appliance gives off heat. After positioning the appliance on the worktop, leave a space of at least 3 cm between the surfaces of the appliance and the side and rear walls and at least 15 cm above the coffee maker.
- Water penetrating the appliance could cause damage. Do not place the appliance near taps or sinks.
- The appliance could be damaged if the water it contains freezes. Do not install the appliance in a room where the temperature could drop below freezing point.
- Arrange the power cable in such a way that it cannot be damaged by sharp edges or contact with hot surfaces (e.g. electric hot plates).

Connecting the appliance



Important!

Check that the mains power supply voltage corresponds to the value indicated on the rating plate on the bottom of the appliance.

Connect the appliance to an efficiently earthed and correctly installed socket with a minimum current rating of 10A only. If the power socket does not match the plug on the appliance,

have the socket replaced with a suitable type by a qualified professional.

Using the appliance for the first time

 Please note :

- Coffee has been used to factory test the appliance and it is therefore completely normal for there to be traces of coffee in the mill. The machine is, however, guaranteed to be new.
 - You should customise water hardness as soon as possible following the instructions in the section “Setting water hardness” on page 15.
1. Plug the appliance into the mains socket and place the main switch on the back of the appliance in the I position (fig. 1).

You must first choose the language (the languages scroll through at intervals of about 3 seconds).

2. When English appears, press the **OK** button for a few seconds (fig. 2). Once the language has been saved, the message “ENGLISH SET” is displayed.

Follow the instructions indicated by the appliance:

3. “FILL TANK”: remove the water tank, fill to the MAX line with fresh water then replace in the appliance (fig. 3).
4. “INSERT WATER SPOUT”: Check that the hot water spout is inserted on the nozzle and place a container with a minimum capacity of 100 ml underneath (fig. 4).
5. “Hot water Confirm?”: Press the **OK** button (fig. 2). “PLEASE WAIT” is displayed and the appliance begins to deliver water from the hot water spout.

The appliance ends the first start up procedure, then the message “TURNING OFF, PLEASE WAIT” is displayed and the appliance goes off.

The coffee maker is now ready for normal use.

 Please note:

- When using the appliance for the first time, you need to make 4/5 cups of coffee or 4/5 cappuccinos before the appliance starts to give satisfactory results.

TURNING THE APPLIANCE ON

 Please note:

Before turning the appliance on, make sure the main switch on the back of the appliance is in the I position (fig. 1).

Each time the appliance is turned on, it performs an automatic preheat and rinse cycle which cannot be interrupted.

The appliance is ready for use only after completion of this cycle.

 Danger of burns!

During rinsing, a little hot water comes out of the coffee spouts and is collected in the drip tray underneath.

Avoid contact with splashes of water.

- To turn the appliance on, press the  button (fig. 5). The message “HEATING UP, PLEASE WAIT” is displayed.

After heating, the message “RINSING” is displayed. As well as heating the boiler, the appliance also heats the internal circuits by circulating hot water.

The appliance is at temperature when the message “READY STANDARD TASTE” is displayed.

TURNING THE APPLIANCE OFF

Each time the appliance is turned off, it performs an automatic rinse cycle which cannot be interrupted.

 Important!

To avoid damaging the appliance, always press the  button to turn off.

 Danger of burns!

During rinsing, a little hot water flows from the coffee spouts.

Avoid contact with splashes of water.

To turn the appliance off, press the  button (fig. 5).

 Please note:

If the appliance is not used for an extended period, place the main switch in the 0 position (fig. 6).

Never place the main switch in the 0 position while the appliance is on.

MENU SETTINGS

The following menu items can be selected: Clock, Start, Auto-start, Descale, Temperature, Off after, Water hardness, Default values.

To access the settings menu, press the **MENU** button. The light on the button comes on.

Clock

To adjust the time on the display, proceed as follows:

1. Access the menu and press the **NEXT** button until “CLOCK” is displayed;
2. Press the **CHANGE** button to change the time (hold the button down to change the time rapidly). When you have finished, release the button. The time flashes.
3. Press the **OK** button to confirm;
4. Press the **MENU** button to exit the menu. The light on the button goes off.

The time displayed when the machine is off (stand-by) is now set.

Turning on

Once “AUTO-START Yes” has been enabled, the auto-start time must be set as follows:

1. Access the menu and press the **NEXT** button until "START" is displayed.
2. Press the **CHANGE** button to change the start time (hold the button down to change the time rapidly). When you have finished, release the button. The auto-start time flashes on the display.
3. Press the **OK** button to confirm.
4. To exit the menu, press the **MENU** button. The light on the button goes out.

The auto-start time has been programmed.

Auto-start

You can set the auto-start time in order to have the appliance ready at a certain time (for example in the morning) so you can make coffee immediately.



Please note!

To enable this function, **the time must be set correctly** (see previous section "Clock").

To set the auto-start time, proceed as described in the section below.

1. Access the menu and press the **NEXT** button until "AUTO-START No" or "AUTO-START Yes" (if the function has been enabled) is displayed;
2. Press the **CHANGE** button to change the selection. The new selection flashes on the display;
3. Press the **OK** button to confirm;

To set the auto-start time, proceed as described in the section below.

The  symbol is displayed alongside the clock to indicate that auto-start has been programmed (in stand-by).

Descaling

For instructions on descaling, see page 15

Temperature

To modify the temperature of the water used to make the coffee, proceed as follows:

1. Access the menu and press the **NEXT** button until "TEMPERATURE" is displayed;
2. Press the **CHANGE** button until the required temperature (low, medium, high, maximum) is displayed;
3. Press the **OK** button to confirm;
4. Press the **MENU** button to exit the menu. The light on the button goes off.

Off after (Stand-by)

The auto-off time can be changed so that the appliance switches off after 15 or 30 minutes, or after 1, 2 or 3 hours.

1. Access the menu and press the **NEXT** button until "OFF AFTER" is displayed;

2. Press the **CHANGE** button to select the required period of time;
3. Press the **OK** button to confirm;
4. Press the **MENU** button to exit the menu. The light on the button goes off.

Auto-off is programmed.

Water hardness

For instructions on setting water hardness, see page 15.

Default values (reset)

This resets all menu settings and programmed quantities back to the default values (with the exception of the language which remains as set).

1. Access the menu and press the **NEXT** button until "DEFAULT VALUES No" is displayed;
2. Press the **CHANGE** button to change the selection to "DEFAULT VALUES Yes". The new selection flashes on the display;
3. Press the **OK** button to restore the original settings.

Setting the language

For instructions on setting the language, see page 16.

MAKING COFFEE

Selecting the coffee taste

The appliance is set by default to make coffee with a standard taste.



You can also choose one of these tastes:

-  Extra-mild taste
-  Mild taste
-  Standard taste
-  Strong taste
-  Extra-strong taste

To change the taste, press the  button (fig. 7) repeatedly until the required taste is displayed.

Selecting the quantity of coffee in the cup

To choose the coffee quantity, press the corresponding button (fig. 8) according to the following table:

Corresponding coffee	QUANTITY (ML)
 SHORT	40 (programmable from 20 to 180)
 STANDARD	90 (programmable from 20 to 180)

 LONG	120 (programmable from 20 to 180)
--	-----------------------------------

i Please note:

To make two cups of coffee, press the button twice rapidly.

Programming quantity

To modify the quantity of coffee delivered, proceed as follows:

1. Place a cup under the coffee spouts (fig. 9).
2. Keep the button corresponding to the quantity to be modified pressed until the message "PROGRAM QUANTITY" is displayed and coffee delivery begins. Then release the button.
3. As soon as the coffee in the cup reaches the required level, press the same button again.

The quantity set has now been programmed.

Regulating the coffee mill

The coffee mill is set by default to prepare coffee correctly and should not require regulating initially.

However, if after making the first few coffees you find that delivery is either too fast or too slow (a drop at a time), this can be corrected by adjusting the grinding adjustment knob (fig. 10).

i Please note!

The grinding adjustment knob must only be turned when the coffee mill is in operation.

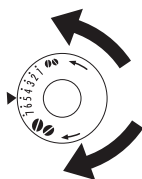

For faster delivery (not a drop at a time), turn one click clockwise towards "7" (coarser ground coffee).

For fuller bodied creamier coffee, turn one click anticlockwise towards "1" (finer ground coffee).

These adjustments will only be evident after at least 2 cups of coffee have been delivered.

If delivery is still too fast or too slow, repeat the correction, turning the knob another click.

Manual rinsing

⚠ Danger of burns!

During rinsing, a little hot water comes out of the coffee spouts and is collected in the drip tray underneath. Avoid contact with splashes of water.

For hotter coffee, before making the coffee rinse the appliance by pressing the  button. Hot water flows out of the spout, heating the internal circuit and making the coffee delivered hotter.

Tips for a hotter coffee

For a hotter coffee, you are recommended to:

- before delivering coffee, perform a rinse cycle, see previous section "Manual rinse".
- place the cups on the cup warmer until they are warm;
- warm the cups by rinsing them with hot water (using the hot water function);
- set a higher coffee temperature in the menu.

Preparing coffee using coffee beans

⚠ Important!

Do not use caramelised or candied coffee beans as they could stick to the coffee mill and make it unusable.

1. Fill the container with coffee beans (fig. 11).
2. Place under the coffee spouts:
 - 1 cup, if you want 1 coffee (fig. 9);
 - 2 cups, if you want 2 coffees (fig. 12);
3. Lower the spouts as near as possible to the cup. This makes a creamier coffee (fig. 13).
4. Press the button corresponding to the coffee required once or twice (fig. 8).
5. Once the coffee has been made, the appliance prepares for use again.

i Please note:

- While the machine is making coffee, delivery can be interrupted at any moment by pressing one of the coffee buttons.
- At the end of delivery, to increase the quantity of coffee in the cup, just press (within 3 seconds) one of the coffee buttons.

Once the coffee has been made, the appliance is ready to use again.

⚠ Important!

If the coffee is delivered a drop at a time, too fast and not creamy enough or too cold, read the tips in the "Troubleshooting" section on page 17.

Various alarm messages could be displayed while the machine is in use. Their meaning is explained in the section "Displayed messages" (page 16).

Making coffee using pre-ground coffee

⚠ Important!

- Never add pre-ground coffee when the machine is off or it could spread through the inside of the machine and dirty it. This could damage the appliance.

⚠ Never use more than one level measure or it could dirty the inside of the machine or



block the funnel.

 Please note!

If you use pre-ground coffee, you can only make one cup of coffee at a time.

1. Press the  button (fig. 14) until "READY PRE-GROUND" is displayed.
2. Put one level measure of pre-ground coffee into the funnel (fig. 15).
3. Place a cup under the coffee spouts (fig. 9).
4. Press one of the coffee buttons (fig. 8).
5. Preparation begins.

Once the coffee has been made, the appliance prepares for use again. To disable the pre-ground coffee function, press the  button again.

MAKING DRINKS WITH MILK

 Please note!

To avoid producing milk with poor froth or large bubbles, always clean the milk lid and hot water nozzle as described in the section "Cleaning the milk container" on pages 12 and 15.

Filling and attaching the milk container

1. Remove the lid (fig. 16);
2. Fill the milk container with a sufficient quantity of milk, not exceeding the MAX level marked on the container (fig. 17).

 Please note!

- For a denser creamier froth, use skimmed or partially skimmed milk at refrigerator temperature (about 5°C).
3. Make sure the milk intake tube is correctly inserted in the bottom of the milk container lid (fig. 18).
 4. Replace the lid on the milk container.
 5. Remove the hot water spout from the nozzle (fig. 19).
 6. Attach the container to the nozzle and push as far as it will go (fig. 20).

Making cappuccino

1. Attach the milk container (see previous section) and place a sufficiently large cup under the coffee spouts and milk spout.
2. Press the  button (fig. 21). The appliance now displays: "CAPPUCCINO, PLEASE WAIT".

After a few seconds, frothed milk flows out of the milk spout into the cup below. Milk delivery stops automatically and coffee delivery begins.

 Please note!

If during delivery you want to stop preparing milk, press the  button or interrupt preparation of the coffee by pressing one of the coffee buttons.

The cappuccino is ready. Sweeten to taste and, if desired, sprinkle the froth with a little cocoa powder.

Making frothed milk

To make frothed milk, proceed as described in the previous section, pressing the  button (fig. 21) twice consecutively (within two seconds). The appliance displays "FROTHED MILK".

Cleaning the milk container after use

 Important! Danger of burns

When cleaning the internal tubes of the milk container, a little hot water leaks out of the frothed milk tube (B5). Avoid contact with splashes of water.

When "PRESS CLEAN" flashes on the display (each time you use a milk function):



1. Leave the milk container in the machine (you do not need to empty it);
2. Place a cup or other recipient under the frothed milk spout.
3. Press the "CLEAN" button (fig. 22) and hold it down for at least 8 seconds. The message "CLEANING UNDERWAY" is displayed.
4. Remove the milk container and always clean the nozzle with a sponge (fig. 23).

 Please note!

- When "PRESS CLEAN" flashes on the display, you can still prepare any type of coffee or milk. If you have to make a number of drinks with milk, wait until you have delivered the last cup before cleaning the container.
- The milk left in the container can be kept in the refrigerator.
- In some cases, to clean you must wait for the appliance to heat up, holding the CLEAN button down.

Programming the quantities of coffee and milk in the cup

The appliance is set by default to automatically deliver standard quantities. To change these quantities, proceed as follows:

1. Place a cup under the coffee spouts and milk spout.
2. Press the  button and hold it down for at least 8 seconds until the message "MILK FOR CAPPUCCINO PROGRAM QUANTITY" is displayed.
3. Release the button. The appliance starts delivering milk.
4. When the required quantity of milk has been delivered into the cup, press the  button again.
5. After a few seconds, the appliance starts delivering coffee

into the cup and the message "COFFEE F. CAPPUCCINO PROGRAM QUANTITY" is displayed.

- As soon as the coffee in the cup reaches the required level, press the  button again. Coffee delivery stops.

The machine is now reprogrammed with the new quantities.

HEATING WATER



Preparation



Important! Danger of burns.

Never leave the machine unsupervised while delivering hot water.

The hot water spout becomes hot while water is delivering and must be handled by the handle only.

- Place a container under the cappuccino maker (as close as possible to avoid splashes) (fig. 4).
- Press the  button (fig. 2). The message "HOT WATER" is displayed.
- Water flows out of the spout. Delivery stops automatically after 250ml.
- To interrupt delivery of hot water manually, press the  button again.





Please note!

- You should not deliver hot water for more than 3 minutes at a time.

Changing the quantity

The appliance is set by default to automatically deliver 250ml.

To modify these quantities, proceed as follows:

- Position a container under the spouts.
 - Press the  button until the message "HOT WATER PROGRAM QUANTITY" is displayed.
- When the hot water in the cup reaches the required level, press the  button again.

The machine is now reprogrammed with the new quantities.

CLEANING



Important!

- Do not use solvents, abrasive detergents or alcohol to clean the appliance. With De'Longhi superautomatic coffee makers, you need not use chemical products to clean the machine.
- None of the components can be washed in a dishwasher apart from the milk container (B).
- Do not use metal objects to remove encrustations or coffee deposits as they could scratch metal or plastic surfaces.

Cleaning the coffee maker

The following parts of the machine must be cleaned regularly:

- coffee grounds container (A15),
- drip tray (A13),
- inside the machine, accessible after opening the service door (A14),
- water tank (A10),
- coffee spouts (A16) and hot water nozzle (A9),
- pre-ground coffee funnel (A7),
- infuser (A18),
- milk container (B)

Cleaning the coffee grounds container

When "EMPTY GROUNDS CONTAINER" is displayed, the grounds container must be emptied and cleaned.

Until the grounds container has been cleaned, the appliance continues to display the message and coffee cannot be made.

Even if not full, the empty grounds container message is displayed 72 hours after the first coffee has been prepared. For the 72 hours to be calculated correctly, the machine must never be turned off with the main switch in the 0 position.

- Open the service door on the front of the appliance (fig. 24), extract the drip tray (fig. 25), empty and clean.
- Empty the grounds container and clean thoroughly to remove all residues left on the bottom.



Important!

When removing the drip tray, the grounds container must be emptied, even if it contains few grounds.

If this is not done, when you make the next coffees, the grounds container may fill up more than expected and clog the machine.

Cleaning the drip tray



Important!

If the drip tray is not emptied regularly, the water could overflow from the edge and seep inside or around the machine. This could damage the machine, the surface it rests on or the surrounding area.

The drip tray is fitted with a level indicator (red) showing the level of water it contains (fig. 26).

Before the indicator protrudes from the cup tray, the drip tray must be emptied and cleaned.

To remove the drip tray:

- Open the service door (fig. 24);
- Remove the drip tray and the grounds container (fig. 25);
- Empty the drip tray and grounds container and wash them;
- Replace the drip tray complete with grounds container;
- Close the service door.

Cleaning the inside of the machine

Danger of electric shock!

Before cleaning internal parts, the machine must be turned off (see section "Turning off" on page 9) and unplugged from the mains power supply. Never immerse the coffee maker in water.

1. Check regularly (about every 100 coffees) that the inside of the appliance (accessible after removing the drip tray) is not dirty. If necessary, remove coffee deposits with a toothpick.
2. Remove the residues with a vacuum cleaner (fig. 27).

Cleaning the water tank

1. Clean the water tank (A10) regularly (about once a month) with a damp cloth and a little mild washing up liquid.
2. After cleaning the water tank rinse it thoroughly to remove all washing up liquid residues.

Cleaning the coffee spouts

1. Clean the coffee spouts with a sponge or cloth (fig. 28).
2. Check the holes in the coffee spout are not blocked. If necessary, remove coffee deposits with a toothpick (fig. 29).

Cleaning the pre-ground coffee funnel

Check regularly (about once a month) that the pre-ground coffee funnel (A7) is not blocked.

If necessary, remove coffee deposits with the brush provided (B8).

Cleaning the infuser

The infuser (A18) must be cleaned at least once a month.

Important!

The infuser may not be extracted when the machine is on.

1. Make sure the machine is correctly turned off (see Turning off, page 9).
2. Open the service door (fig. 24).
3. Remove the drip tray and grounds container (fig. 25);
4. Press the two red release buttons inwards and at the same time pull the infuser outwards (fig. 30).

Important!

RINSE WITH WATER ONLY

NO WASHING UP LIQUID - NO DISH WASHER

Do not use washing up liquid to clean the infuser as it could cause damage.

5. Soak the infuser in water for about 5 minutes, then rinse under the tap.
6. After cleaning, replace the infuser by sliding it onto the in-

ternal support and pin at the bottom, then push the PUSH symbol fully in until it clicks into place.

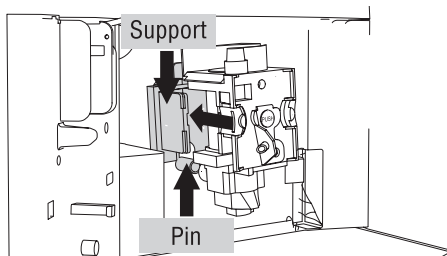

Please note!

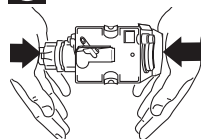

If you encounter difficulty inserting the infuser, before inserting it you must adapt it to the right dimension by pressing it forcefully from the bottom and

top as shown in the figure.

7. Once inserted, make sure the two red buttons have snapped out.
8. Replace the drip tray and grounds container.
9. Close the service door.

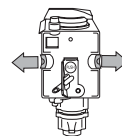

Cleaning the milk container

Clean the milk container each time you prepare milk as described below:

1. Turn the lid of the milk container clockwise then remove it.
2. Remove the milk spout and intake tube.
4. Wash all the components thoroughly with hot water and mild washing-up liquid.

All components can be washed in a dishwasher, placing them in the top basket of the dishwasher.

Make sure there are no milk residues left inside the holes.

5. Check that the intake tube and spout are not clogged with milk residues.
6. Replace the froth regulator, milk spout and intake tube.
7. Replace the lid on the milk container, turning it anticlockwise to hook it in place.

DESCALING

Descale the machine when the message "DESCALE" flashes on the display.

Important!

- Descaler contains acids which may irritate the skin and eyes. It is vital to respect the manufacturer's safety warnings given on the descaler pack and the warnings relating

to the procedure to follow in the event of contact with the skin and eyes.

- You should use De'Longhi descaler only. Using unsuitable descaler and/or performing descaling incorrectly may result in faults not covered by the manufacturer's guarantee.

1. Turn the machine on.
2. Access the menu and press the **NEXT** button until "DESCALE No" is displayed;
2. Press the **CHANGE** button;
3. "DESCALE Yes" is displayed.
4. Press the **OK** button to confirm. "DESCALE COMPLETE PRESS OK" is displayed.
5. Pour the descaler diluted with water (respecting the proportions indicated on the descaler pack) into the water tank and put back in the machine.
Place an empty container with a minimum capacity of 1.8 litres under the hot water spout.



Important! Danger of burns

Hot water containing acid flows out of the hot water spout.
Avoid contact with splashes of water.

6. Press the **OK** button;
7. The message "DESCALE" is displayed. The descaling programme starts and the descaler liquid comes out of the water spout. The descale programme automatically performs a series of rinses and pauses to remove limescale deposits from inside the machine.

After about 30 minutes, the message "RINSING FILL TANK" is displayed.

8. The appliance is now ready for rinsing through with clean water. Remove the water tank, empty, rinse under running water, fill with clean water and replace. "RINSING PRESS OK" is displayed.
9. Empty the container used to collect the descaler solution and replace it under the cappuccino maker.
10. Press the **OK** button to start rinsing. Hot water flows out of the spout and the message "RINSING" is displayed.
11. When the water tank is completely empty, the message "RINSING COMPLETE PRESS OK" is displayed.
12. Press the **OK** button.

The appliance is ready to use.



Please note!

If the descaling cycle is not completed correctly (e.g. lack of electricity) we recommend repeating the cycle.

SETTING WATER HARDNESS

The DESCALE message is displayed after a period of time established according to water hardness.

The machine is set by default for a hardness value of 4.

The machine can also be programmed according to the actual hardness of the mains water in the various regions, varying the frequency with which the message is displayed.

Measuring water hardness

1. Remove the "TOTAL HARDNESS TEST" indicator paper from its pack.
2. Immerse the paper completely in a glass of water for one second.
3. Remove the paper from the water and shake lightly. After about a minute, 1, 2, 3, or 4 red squares form, depending on the hardness of the water. Each square corresponds to one level.

Level 1 

Level 2 

Level 3 

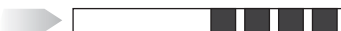
Level 4 

Set water hardness

1. Access the menu and press the **NEXT** button until "WATER HARDNESS ●●●●" is displayed;
2. Press the **CHANGE** button to select the level of hardness measured on the indicator paper (see previous section). When you have finished, the new selection flashes on the display.
3. Press the **OK** button to confirm the setting.
4. Press the **MENU** button to exit the menu. The light on the button goes off.

The machine is now reprogrammed with the new water hardness setting.

SET LANGUAGE

To change the language, with the machine on, press the **CHANGE** button for at least 5 seconds until the appliance displays the installation message in various languages.

Choose the required language as described in the section "Using the appliance for the first time".

TECHNICAL SPECIFICATION

Voltage:	220-240 V~ 50/60 Hz max. 10A
Absorbed power:	1350W
Pressure:	1,5 MPa (15 bar)
Water tank capacity:	1,8 L
Size: LxHxD:	280x375x360mm
Cable length:	1500 mm
Weight:	10,5 Kg
Beans container capacity:	200 g

CE The appliance complies with the following EC directives:

- Low Voltage Directive 2006/95/EC and subsequent amendments;
- EMC Directive 2004/108/EC and subsequent amendments;
- European Standby Regulation 1275/2008
- Materials and accessories coming into contact with food conform to EEC regulation 1935/2004.

DISPOSAL



In compliance with European directive 2002/96/EC, the appliance must not be disposed of with household waste, but taken to an authorised waste separation and recycling centre.

DISPLAYED MESSAGES

DISPLAYED MESSAGE	POSSIBLE CAUSE	SOLUTION
FILL TANK	Insufficient water in the tank.	Fill the tank with water and/or insert it correctly, pushing it as far as it will go until it clicks into place.
GROUND TOO FINE ADJUST MILL <i>alternating with...</i> INSERT WATER SPOUT AND PRESS OK	The grinding is too fine and the coffee is delivered too slowly or not at all.	Repeat coffee delivery and turn the grinding adjustment knob one click clockwise towards "7" while the coffee mill is in operation. If after making at least 2 coffees delivery is still too slow, repeat the correction procedure, turning the grinding adjustment knob another click until delivery is correct. If the problem persists, press the OK button to deliver water from the spout until it flows out normally.
INSERT WATER SPOUT	The water spout is not inserted or is inserted incorrectly.	Insert water spout as far as it will go.
EMPTY GROUNDS CONTAINER	The grounds container is too full or more than 3 days have passed since you last made coffee (this guarantees correct hygiene of the machine).	Empty the grounds container and clean, then replace. Important: when removing the drip tray, the grounds container must be emptied, even if it contains few grounds. If this is not done, when you make the next coffees, the grounds container may fill up more than expected and clog the machine.
INSERT GROUNDS CONTAINER	After cleaning, the grounds container has not been replaced.	Open the service door, remove the drip tray and insert the grounds container.
ADD PRE-GROUND COFFEE	The "pre-ground coffee" function has been selected without placing any pre-ground coffee in the funnel.	Place pre-ground coffee in the funnel or deselect the "pre-ground" function.

DESCALE	The machine must be descaled.	The descaling procedure described in the "Descaling" section needs to be performed as soon as possible.
LESS COFFEE	Too much coffee has been used.	Select a milder taste or reduce the quantity of pre-ground coffee.
FILL BEANS CONTAINER	The coffee beans have run out.	Fill the beans container
	The pre-ground coffee funnel is clogged.	Empty the funnel with the help of a brush as described in the section "Cleaning the pre-ground coffee funnel".
INSERT INFUSER ASSEMBLY	The infuser has not been replaced after cleaning.	Insert the infuser as described in the paragraph "Cleaning the infuser".
CLOSE DOOR	The service door is open	Close the service door.
INSERT MILK CONTAINER	The milk container is not inserted correctly.	Insert the milk container as far as it will go.
PRESS CLEAN	Milk has been delivered recently and the tubes inside the milk container must be cleaned.	Press the CLEAN button and hold it down for at least 8 seconds. The message "CLEANING UNDERWAY" is displayed.
GENERAL ALARM	The inside of the appliance is very dirty.	Clean the inside of the appliance thoroughly, as described in the section "Cleaning and maintenance". If the message is still displayed after cleaning, contact a service centre.

TROUBLESHOOTING

Below is a list of some of the possible malfunctions.

If the problem cannot be resolved as described, contact a Service Centre.

PROBLEM	POSSIBLE CAUSE	SOLUTION
The coffee is not hot	The cups were not preheated.	<ul style="list-style-type: none"> Leave the cups on the cup warmer at least 20 minutes to warm up. Warm the cups by rinsing them with hot water (using the hot water function).
	The infuser has cooled down because 2/3 minutes have elapsed since the last coffee was made.	Before making the coffee, heat the infuser by performing a rinse cycle.
	A low coffee temperature is set.	Set a high coffee temperature in the menu.
The coffee is not creamy enough.	The coffee is ground too coarsely.	Turn the grinding adjustment knob one click anticlockwise towards "1" while the coffee mill is in operation (fig. 8). Continue one click at a time until coffee delivery is satisfactory. The effect is only visible after delivering 2 coffees.
	Wrong type of coffee	Use a type of coffee for espresso coffee makers.

The coffee is delivered too slowly or a drop at a time.	The coffee is ground too finely.	Turn the grinding adjustment knob one click clockwise towards "7" while the coffee mill is in operation (fig. 11). Continue one click at a time until coffee delivery is satisfactory. The effect is only visible after delivering 2 coffees.
The coffee does not come out of the spouts, but from around the service door.	The holes in the spouts are clogged with dry coffee dust.	Clean the spouts with a toothpick, sponge or hard bristled kitchen brush.
	The coffee guide inside the service door is blocked and cannot swing.	Thoroughly clean the coffee guide, particularly near the hinges.
Coffee does not come out of one of the spouts.	The spouts are blocked.	Clean the spouts with a toothpick (fig. 26).
The milk contains bubbles or squirts out of the milk spout.	The milk is not cold enough or is not semi-skimmed.	You should ideally use skimmed or semi-skimmed milk at refrigerator temperature (about 5°C). If the result is not as you wished, try changing brand of milk.
	The milk container lid is dirty.	Clean the milk container lid as described in the section "Cleaning the milk container".
The milk is not frothed	The milk container lid or froth adjustment knob is dirty	Clean the milk container lid and knob as described in the section "Cleaning the milk container".
The appliance does not come on.	It is not plugged into the mains socket.	Plug into the mains socket.
	The main switch is not turned on.	Place the main switch in the I position (fig. 29).
The milk does not come out of the milk spout.	The milk container lid is dirty.	Clean the milk container lid as described in the section "Cleaning the milk container".