

Proudly distributed by  
**De'Longhi Australia Pty Limited**  
P.O. BOX 4540  
CASULA MALL NSW 2170  
Customer Service Ph: 1800 126 659  
Fax: 1800 706932  
[www.delonghi.com.au](http://www.delonghi.com.au)  
e-mail: [delonghi@delonghi.com.au](mailto:delonghi@delonghi.com.au)

**De'Longhi New Zealand Limited**  
25 Carbine Road  
Mt Wellington  
Auckland, New Zealand  
P.O. Box 58-056 Botany  
MANUKAU 2163  
Customer Service Ph: 0508 200 300  
Fax: 0508 200 301  
[www.delonghi.com.nz](http://www.delonghi.com.nz)  
e-mail: [delonghi@delonghi.com.nz](mailto:delonghi@delonghi.com.nz)

---

FH1163 FH1363

MULTIFRY



---

**DeLonghi**

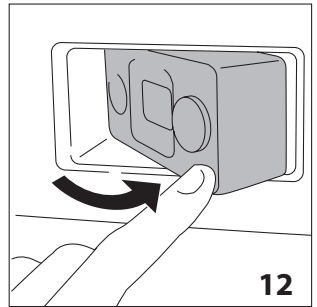
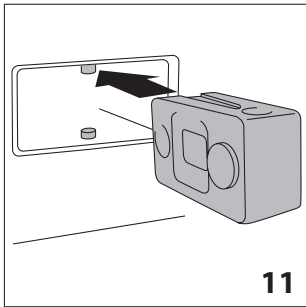
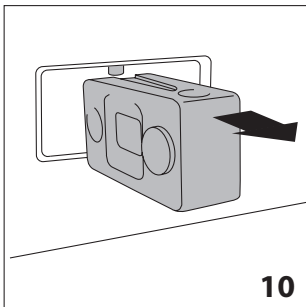
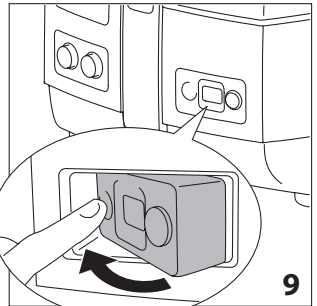
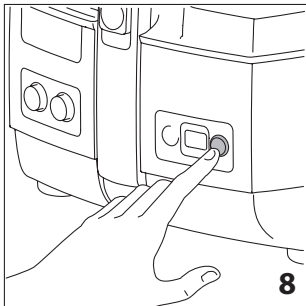
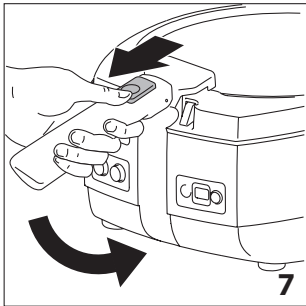
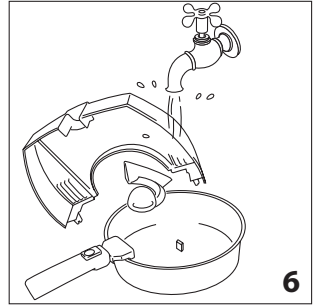
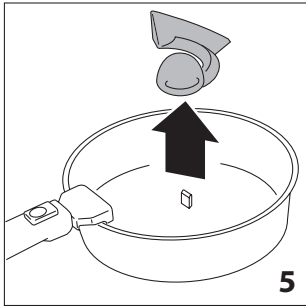
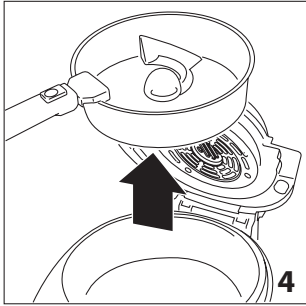
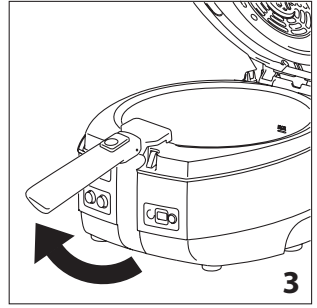
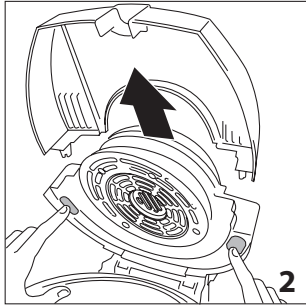
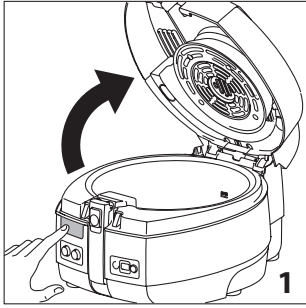

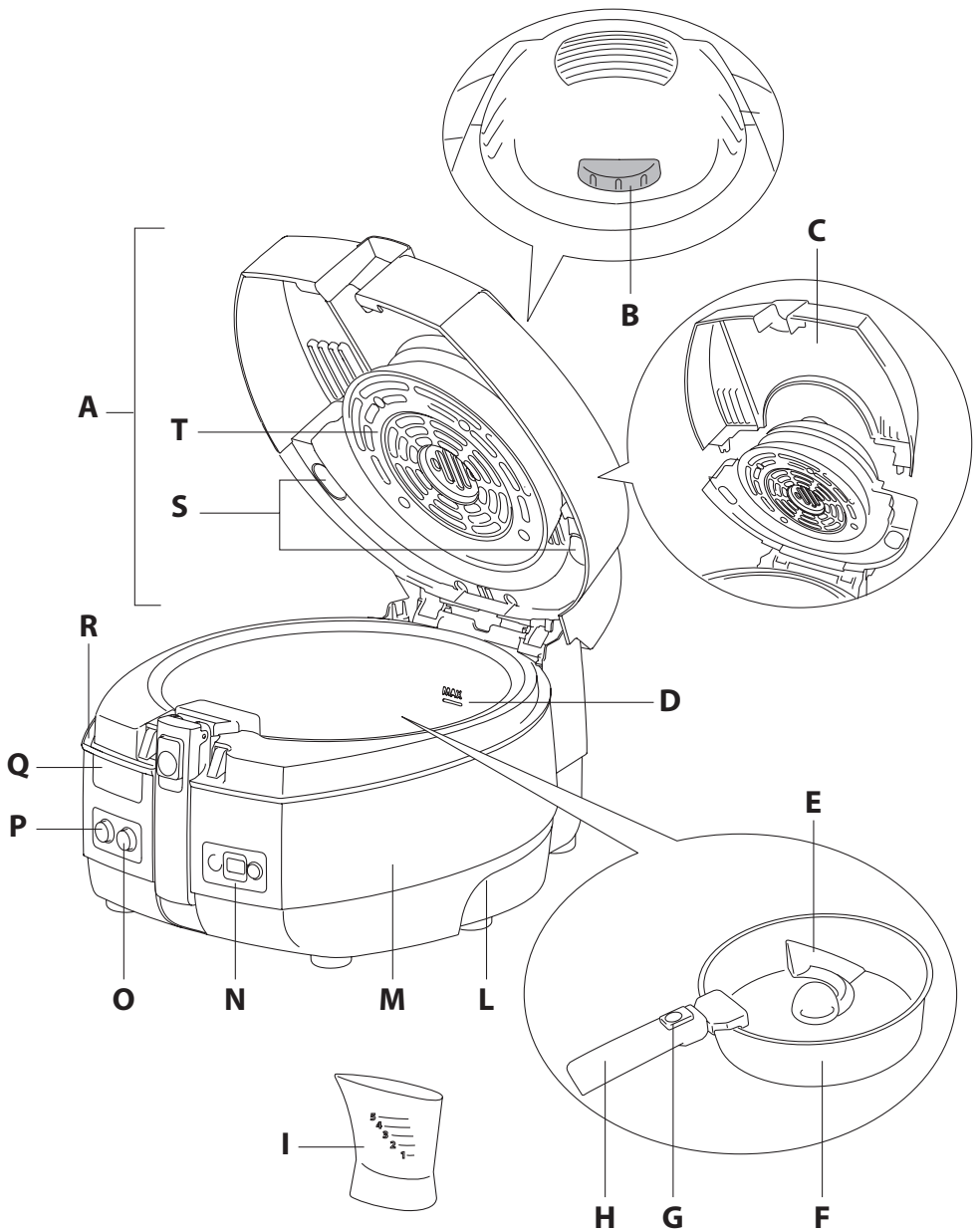

## IMPORTANT SAFEGUARDS

Read all the Instruction for Use carefully before using the appliance. Keep this Instruction for Use.

- If the power cable is damaged, it must be replaced by the manufacturer or the manufacturer's Customer Experience in order to avoid all risk.
- Never immerse the appliance in water.
- When in operation, accessible external surfaces and the lid could become very hot. Always use the handgrip, handles and buttons.

Use oven gloves if necessary.

- This electrical appliance operates at high temperatures which could cause burns.
- This appliance can be used by children aged from 8 years and above and persons with reduced physical, sensory or mental capabilities or lack of experience and knowledge if they have been given supervision or instruction concerning use of the appliance in a safe way and understand the hazards involved.

Children should be supervised to ensure that they do not play with the appliance. Cleaning and user maintenance shall not be made by children, unless they are more than eight years old and under constant supervision.

Keep the appliance and power cable away from children under eight years of age.

- Do not preheat the appliance when empty.
- Do not use the appliance without food,

you might damage it.

- This is an household appliance only. It is not intended to be used in: staff kitchen areas in shops, offices and other working environments; farm houses; by clients in hotels, motels and other residential type environments; bed and breakfast type environments.
- The appliance must not be operated by a timer or a separate remote control system.



Failure to observe the warning may result in life threatening injury by electric shock.

- Before using the appliance, check that the voltage of the mains power supply corresponds to the value indicated on the appliance rating plate.
- Connect the appliance to an efficiently earthed socket with a minimum current rating of 10A only. The manufacturer declines all liability in the event that this important accident-prevention rule is not respected.



Failure to observe the warnings could result in scalds or burns.

- While in operation, the appliance becomes hot. DO NOT LEAVE WITHIN REACH OF CHILDREN.
- Move the appliance by the handles only. Never move the appliance using the bowl handgrip.
- Never leave the power cable hanging from the edge of the surface the appliance is resting on where it could be grasped by a child or get in the way of the user.
- Hot steam may come out of the vents. Take great care!



Failure to observe the warnings may result in life threatening injury or damage to the appliance.

- Never locate the appliance near sources of heat.
- The bowl fits automatically onto the central pin. To avoid damage, never rotate it manually to find the right position.
- Never insert anything into the ventilation openings. Make sure they are unobstructed.
- Do not fill the bowl with liquid above the MAX level (R).
- Do not put more oil in the bowl than the maximum level on the oil measure (level 5)

## **Please note:**

This symbol identifies important advice or information for the user.

- Before using the appliance for the first time, remove any paper and other material inside the oven such as protective cardboard, booklets, plastic bags, etc.
- Before using the appliance for the first time, wash the bowl, paddle and lid in hot water and washing up liquid. At the end of the operation, dry all components thoroughly and remove any water left in the bottom of the bowl.
- It is normal for the appliance to give off a “new” smell when used for the first time. Ventilate the room.
- The appliance must be kept at a distance of at least 20 cm from the mains power socket to which it is connected.

## TECHNICAL DATA

	<b>FH1163</b>	<b>FH1363</b>
size (LxHxD):	395x325x270mm	395x325x290
weight:	4.8kg	5kg

For further information, see the rating plate on the appliance.



The appliance complies with the following EU directives:

- Low Voltage Directive 2006/95/EC and subsequent amendments;
- This appliance complies with EC directive 2004/108/EC on electromagnetic compatibility and European regulation no. 1935/2004 of 27/10/2004 on food contact materials.
- European Stand-by Regulation 1275/2008.

## DISPOSAL



In compliance with European directive 2002/96/EC, the appliance must not be disposed of with household waste, but taken to an authorised waste separation and recycling centre.

## DESCRIPTION OF APPLIANCE

A	Lid
B	Thermostat dial
C	Removable viewing window
D	Maximum level MAX
E	Paddle
F	Ceramic coated bowl
G	Handgrip slide
H	Bowl handgrip
I	Oil measure (level from 1 to 5)
L	Handle for lifting the appliance
M	Appliance body

N	Removable timer
O	Bottom heating element button
P	ON/OFF button with light
Q	Lid open button
R	Condensate tray
S	Viewing window release buttons
T	Hot air discharge grille

## SETTING UP THE APPLIANCE



**Please note:** Before using the appliance for the first time, wash the bowl (F), paddle (E) and removable viewing window (C) in hot water and neutral washing up liquid.

Proceed as follows:

- Open the lid (A) by pressing button (Q) (fig. 1).
- Release the removable viewing window (C) by pressing the two buttons (S) (fig. 2).
- Lift the bowl handgrip (H) until you hear a “click” (fig. 3).
- Extract the bowl (F) by pulling upwards (fig. 4).
- Extract the paddle (E) from its housing (fig. 5).
- Wash the bowl (F), paddle (E) and removable viewing window (C) (fig. 6).
- At the end of the operation, dry all components thoroughly and remove any water left in the bottom of the bowl (F).

## COOKING WITH THE PADDLE



**Please note:** This type of cooking is particularly suitable for cooking potatoes.

- Put the bowl (F) back in the appliance body (M), making sure it is correctly positioned.
- Lower the bowl handgrip (H) using the slide (G) (fig. 7).
- Insert the paddle (E), making sure it is correctly positioned on the pin at the bottom of the bowl.
- Place the ingredients to be cooked in the bowl (F), respecting the quantities given in the cooking tables/recipes.
- If required by the cooking procedure, add oil, referring to the quantities indicated in the cooking tables/recipes and using the measure (I).
- Close the lid (A).
- Plug the appliance into the mains socket.
- Adjust the thermostat dial (B) to the required position (see cooking tables/recipes).
- If required by the cooking procedure, press the bottom heating element button (O) (see the cooking tables/recipes).
- Press the ON/OFF button (P). The light in the button comes on. The lower heating element activates immediately. The upper heating element will turn on when the lid is closed.
- Cooking begins.
- Set the cooking countdown by pressing the button on the

timer (N) (fig. 8). The minutes set appear on the display.

- Immediately afterwards, the numbers begin to flash. This means the cooking time has begun. The last minute is displayed in seconds.
- If you make a mistake, you can set the new cooking time by holding the button down for more than two seconds. When the display has reset, repeat the operation.
- The timer indicates the end of cooking time with two series of beeps separated by a 20 second gap. To turn off the signal, just press the timer button.

 **Please note:** the timer does not turn the appliance off.

 **Please note:** To guarantee best results, the paddle (E) begins to turn a few minutes after cooking begins.

 **Please note:** During cooking, you can lift up the lid (A) to add ingredients or check cooking progress. Ventilation stops briefly, then starts again when you close the lid.

 **Please note:** If the ON/OFF button is on, extracting the bowl turns the appliance off. It starts working again when the bowl is reinserted.

- At the end of cooking, if the bottom heating element (O) has been used, press the bottom heating element button again to turn it off.
- Turn the appliance off by pressing the ON/OFF button (P) again.
- Open the lid (A) and remove the bowl (F) with the cooked food.
- Leave the lid (A) open to allow the appliance to cool faster.

## COOKING WITHOUT THE PADDLE

 **Please note:** This type of cooking is particularly suitable for cooking desserts, cakes, pastries and pizzas.

- Put the bowl (F) back in the appliance (M), making sure it is correctly positioned.
- Lower the bowl handgrip (H) using the slide (G) (fig. 7).
- Place the ingredients to be cooked in the bowl (L), respecting the quantities given in the cooking tables/recipes.
- If required by the cooking procedure, add oil, referring to the quantities indicated in the cooking tables/recipes and using the measure (I).
- Close the lid (A).
- Plug the appliance into the mains socket.
- Adjust the thermostat dial (B) to the required position (see cooking tables/recipes).
- If required by the cooking procedure, press the bottom heating element button (O) (see the cooking tables/recipes).
- Press the ON/OFF button (P). The light in the button comes

on.

The lower heating element activates immediately. The upper heating element will turn on when the lid is closed.

- Cooking begins.
- Set the cooking time by pressing the button on the timer (N) (fig. 8). The minutes set appear on the display.
- Immediately afterwards, the numbers begin to flash. This means the cooking time has begun. The last minute is displayed in seconds.
- If you make a mistake, you can set the new cooking time by holding the button down for more than two seconds. When the display has reset, repeat the operation.
- The timer indicates the end of cooking time with two series of beeps separated by a 20 second gap. To turn off the signal, just press the timer button.

 **Please note:** The timer does not turn the appliance off.

 **Please note:** When cooking without the paddle, the pin on the bottom of the bowl still turns a few minutes after cooking begins.

 **Please note:** During cooking, you can lift up the lid (A) to add ingredients or check cooking progress. Ventilation stops briefly, then starts again when you close the lid.

 **Please note:** If the ON/OFF button is on, extracting the bowl turns the appliance off. It starts working again when the bowl is reinserted.

- At the end of cooking, if the bottom heating element (O) has been used, press the bottom heating element button again to turn it off.
- Turn the appliance off by pressing the ON/OFF button (P) again.
- Open the lid (A) and remove the bowl (F) with the cooked food.
- Leave the lid (A) open to allow the appliance to cool faster.

## EXTRACTING THE TIMER

- To extract the timer (N) from its housing, press the left side of the display, then turn (fig. 9) and pull off (fig. 10).
- To put the timer back, thread it onto the pins in the housing and push as far as it will go until it catches (fig. 11), then turn as shown in fig. 12.

 **Please note:** To replace the timer battery, contact the manufacturer's authorised Customer Experience.

## CLEANING AND MAINTENANCE

 **Danger!** Before cleaning the appliance, always unplug from the mains socket and allow to cool.

Never immerse the appliance in water and never place under running tap water.

If water gets into the appliance, it could cause electric shock.

- Wash the bowl (F), paddle (E) and viewing window (C) thoroughly with hot water and neutral washing up liquid. The bowl is dishwasher safe. Frequent washing could reduce

the properties of the ceramic coating.

- Clean the hot air discharge grille (T) without removing it.



**Please note: Do not use sharp, abrasive or metallic utensils to remove food from the bowl as this can damage the ceramic coating. Clean with a soft cloth and neutral detergent only.**

## TROUBLESHOOTING

Fault	Cause/solution
The appliance does not heat up	The thermal cutout may have tripped. Contact the manufacturer's Customer Experience (the device must be replaced).
The bowl is not positioned correctly and the appliance does not work	Position the bowl correctly
The lid is not properly closed and the appliance does not work	Close the lid
The food is raw at the bottom	Make sure you have pressed the bottom heating element button (O)
The paddle (E) does not turn	Wait for a few minutes after cooking begins

## COOKING TABLES

### Potatoes

Recipe	Type	Quantity	Oil	Cooking time (min)		Paddle	Bottom heating element	Thermostat dial
				FH1163	FH1363			
Standard potatoes cut to 1x1cm thick chips	Fresh	1.7 kg (*)	level 5	-	40-43	YES	ON	4
		1.5 kg (*)	level 4	37-40	37-40	YES	ON	4
		1.25 kg(*)	level 3	32-35	35-38	YES	ON	4
		1 kg (*)	level 2	27-30	25-28	YES	ON	4
		750 g (*)	level 1	23-25	21-23	YES	ON	4
	Frozen	1.5 kg	without	-	42-45	YES	ON	4
		1.25 kg	without	33-36	35-38	YES	ON	4
		1 kg	without	27-30	29-32	YES	ON	4
		750 g	without	24-26	24-26	YES	ON	4
		500 g	without	18-20	18-20	YES	ON	4
Roast potatoes	Fresh	1 kg	level 3	35	35	YES	ON	4
Potato wedges	Frozen	1 kg	without	30	32	YES	ON	4
New potatoes	Frozen	1 kg	without	38	40	YES	ON	4
Croquettes	Frozen	750 g	without	24	26	YES	ON	4

(\*) un-peeled potato weight



## Meat - poultry

Recipe	Type	Quantity	Oil	Cooking time (min)		Paddle	Bottom heating element	Thermostat dial	Tips
				FH1163	FH1363				
Chicken nuggets	Frozen	750 g	without	18	18	YES	ON	4	-
Chicken drumsticks	Fresh	650 g	without	35	35	NO	OFF	4	turn 2-3 times
Chicken breast	Fresh	300 g	without	15	15	NO	ON	4	-
Braised veal	Fresh	600 g	level 2	25	25	YES	ON	4	-
Veal chops	Fresh	3 pcs	without	25	28	NO	OFF	4	turn over after 15 min
Veal spare ribs	Fresh	1200 g	without	35	38	NO	OFF	4	turn 2-3 times
Kebabs	Fresh	800 g	without	22	25	NO	OFF	4	turn 2-3 times
Hamburger	Fresh	4 pcs	without	25	28	NO	OFF	4	turn over after 15 min
Meatballs	Fresh	450 g	without	25	25	YES	ON	4	-

## Fish - shellfish

Recipe	Type	Quantity	Oil	Cooking time (min)		Paddle	Bottom heating element	Thermostat dial
				FH1163	FH1363			
Fish fingers	Frozen	18 pcs	without	20	23	NO	ON	4
Salmon steak	Fresh	400 g	without	20	20	NO	ON	3
Salmon fillet	Fresh	350 g	without	15	18	NO	ON	3
Scallops	Fresh	4 pcs	without	17	20	NO	OFF	3
Cuttlefish	Fresh	8 pcs	level 1	20	20	NO	ON	3
Tiger prawns	Fresh	600 g	level 1	20	20	YES	ON	3
Prawns	Fresh	800 g	level 1	20	20	YES	ON	3

## Vegetables

Recipe	Type	Quantity	Oil	Cooking time (min)		Paddle	Bottom heating element	Thermostat dial
				FH1163	FH1363			
Courgettes	Fresh	600 g	level 5	20-25	20-25	YES	ON	4
Aubergines	Fresh	600 g	level 3	20-25	20-25	YES	ON	4
Mushrooms	Fresh	600 g	level 2	15-20	15-20	YES	ON	4
Asparagus	Fresh	800 g	level 5	25-30	25-30	YES	ON	4

## Snacks - Frozen

Recipe	Type	Quantity	Oil	Cooking time (min)		Paddle	Bottom heating element	Thermostat dial	Tips
				FH1163	FH1363				
Pizza	Fresh	300 g	level 1	32	35	NO	ON	2	oil the pan and turn it through 180° after 20 min
	Frozen	450 g	without	20	25	NO	ON	2	turn through 180° after 15 min
Savoury pies and quiches	Fresh	600 g	without	23	27	NO	ON	3	use greaseproof paper and turn through 180° after 15 min
	Frozen	700 g	without	45	50	NO	ON	2	use greaseproof paper and turn through 180° after 30 min
Mini-pizzas	Frozen	14 pcs	without	20	20	NO	ON	3	use greaseproof paper
Mini-savouries	Frozen	14 pcs	without	25	25	NO	ON	3	use greaseproof paper
Paella	Frozen	600 g	without	15	15	YES	ON	4	mix once
Gnocchi alla sorrentina	Frozen	550 gr	without	13	13	YES	ON	4	mix once
Onion rings	Frozen	12/15 pcs	without	15	15	NO	ON	4	spread evenly on the bottom of the bowl

## Desserts, cakes and pastries

Recipe	Type	Quantity	Oil	Cooking time (min)		Paddle	Bottom heating element	Thermostat dial	Tips
				FH1163	FH1363				
Tarts	Fresh	700 g	without	50	50	NO	ON	2	butter and flour the pan and turn the bottom heating element off after 40 min
Brioches	Frozen	4 pcs	without	35	35	NO	ON	2	use greaseproof paper and turn through 180° after 12-13 min
Biscuits	Fresh	8 pcs	without	18	18	NO	ON	3	use greaseproof paper and turn through 180° after 15 min
Fruit	Fresh	300 g	without	18	18	NO	ON	4	-