



**ELECTRIC OVEN
E012001**

DeLonghi

De'Longhi Appliances
via Seitz, 47
31100 Treviso Italia

Instructions for use

DESCRIPTION OF THE APPLIANCE

- A thermostat dial
- B timer dial
- C indicator light
- D function selector dial
- E glass door
- F bottom heating element
- G flat wire rack

- H drip pan
- I shaped wire rack (if supplied)
- L crumb tray
- M top heating element
- N inside light (if supplied)
- O griddle rack (if supplied)

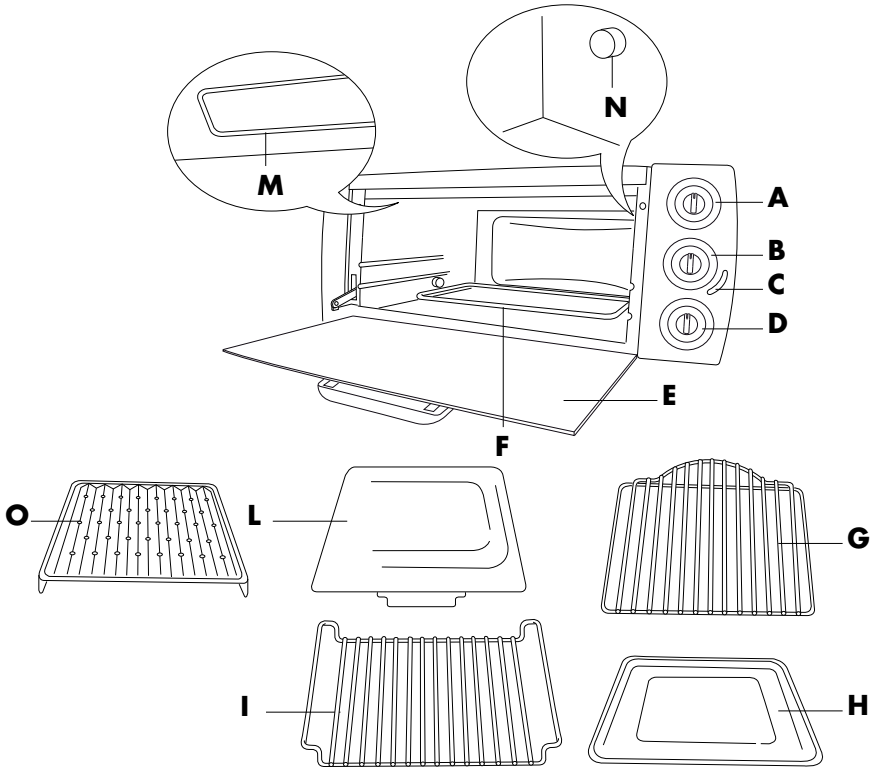

Thank you for choosing this Mini Oven. To get the very best out of your mini oven it is advisable to read these instructions before using the appliance. This is the only way to ensure optimum results and maximum safety. The manufacturer is not liable for damage deriving from the failure to comply with the user instructions.

IMPORTANT WARNINGS

- **Read all the instructions carefully before using the appliance.**
- This oven has been designed to cook food. It must never be used for other purposes, modified or tampered with in any way.
- Place the appliance on a horizontal surface at a height of at

least 85 cm and out of reach of children.

- Wash all accessories thoroughly before use.
- **Before plugging into the mains, make sure that:**
 - the mains voltage corresponds to the voltage indicated on the rating plate;
 - the mains socket has a minimum rating of 16A and an earth wire.

The manufacturer declines all liability in the event that this important accident-prevention rule is not respected.

- Before using the oven for the first time, remove any paper and other material inside the oven such as protective cardboard, booklets, plastic bags, etc.
- Before using for the first time, operate the oven empty with the thermostat at maximum for at least 15 minutes to eli-

minate the "new" smell and any smoke caused by the presence of protective substances applied to the elements before transport. During this operation, ventilate the room.

IMPORTANT: when you have unpacked the appliance, make sure the door is undamaged and working correctly. The door is made from glass and is therefore fragile. If it is visibly chipped, scored or scratched, it should be replaced. While using, cleaning or moving the appliance, avoid slamming or knocking the door violently. Do not pour cold liquid onto the glass while the appliance is hot.

- **When in operation, the door and accessible external surfaces could become very hot. Always use the knobs, handles and buttons. Never touch metal parts or the glass. Use oven gloves if necessary.**
- **This electrical appliance operates at high temperatures which could cause burns.**
- The appliance is not intended for use by persons (including children) with reduced physical, sensory or mental capabilities, or lack of experience and knowledge, unless they have been given supervision or instruction concerning use of the appliance by a person responsible for their safety. Children should be supervised to ensure that they do not play with the appliance.
- Do not move the appliance while in use.
- Do not use the appliance if...
 - the power cable is faulty,
 - the appliance has been dropped, is visibly damaged or malfunctioning.Should this occur, to avoid all risk take the appliance to your nearest authorised service centre. Please see enclosed guarantee.
- Do not let the power cable dangle and avoid touching hot parts of the oven. Never unplug the appliance by pulling on the power cable.
- If you intend to use an extension, make sure it is in good condition, that the plug is earthed and that the cross section of the wires is at least equal to that of the power cable provided with the appliance.
- To avoid all risk of electric shock, never immerse the power cable, plug or appliance itself in water.
- Never position the appliance near heat sources.
- Do not leave inflammable products near the oven or under the work surface where it is located.
- Bread may burn. Never leave the oven unattended during toasting or grilling. Never operate the appliance under a wall cupboard or shelf or near inflammable materials such as curtains, blinds, etc.
- Do not use the appliance as a heat source.
- Never place paper, cardboard or plastic inside the oven and



never rest anything on top of the appliance (utensils, wire racks, other objects).



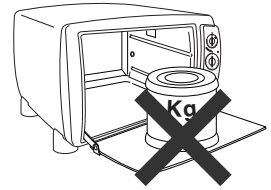





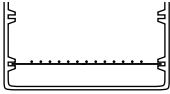

- Never insert anything into the ventilation openings. Make sure they are unobstructed.
- **If food or other parts of the oven catch fire, never try and put out the flames with water. Close the door, unplug from the mains and smother the flames with a damp cloth.**
- This oven is not designed for built-in installation.
- When the door is open, remember:
 - never exert excessive pressure with overly heavy objects or pull the handle downwards;
 - never rest heavy containers or boiling saucepans just out of the oven on the open door.

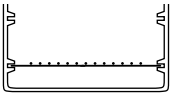

- Given the differences in legislation in force, if the appliance is used in a country other than that where it was bought, have it checked by an authorised service centre.
- For your personal safety, never take the appliance to apart on your own. Always contact an authorised service centre. See enclosed guarantee leaflet.
- This appliance is designed for domestic use only. Professional or inappropriate use, or failure to observe the instructions absolves the manufacturer from all responsibility and invalidates the guarantee.
- When not in use and before cleaning, always unplug the appliance.
- If the supply cord is damaged, it must be replaced by the manufacturer, its service agent or similarly qualified persons in order to avoid a hazard. See enclosed guarantee leaflet.
- This appliance conforms to EC directive 2004/108/EC on Electromagnetic Compatibility and EC regulation no. 1935/2004 of 27/10/2004 on materials intended for contact with food.
- This appliance is not intended to be operated by means of an external timer or separate remote-control system.
- This appliance must be placed to work with the rear side approached to the wall.
- The appliance is designed and produced for domestic use only. It is not suitable for use in: staff kitchens in shops, offices and other workplaces, farm houses, hotels, motels or other holiday accommodation, guest houses

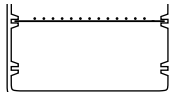
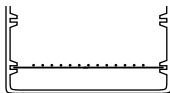
Keep these instructions

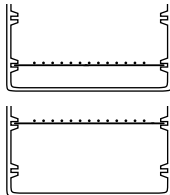
SUMMARY TABLE

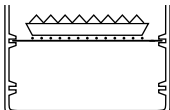
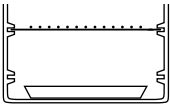
Program	Function selector dial position	Thermostat dial position	Wire rack and accessory position	Notes/Tips
Defrost <i>(only on some models)</i>		•		-
Delicate cooking		60°-220°		-
Keeping food warm		60°		-
Convection oven cooking <i>(only on some models)</i>		60°-220°		Ideal for lasagna, meat, cakes in general, foods that should be crunchy on the surface and bread. For details on how to use the accessories, refer to the tips in the table on page 14.
				
Traditional oven cooking		60°-220°		Ideal for cooking pizza, stuffed vegetables, fish, plum cakes and small poultry. For details on how to use the accessories, refer to the table on page 15.
Grilling		▼▼▼	 only for model with broil rack	Ideal for all types of traditional grilling: hamburgers, frankfurters, kebabs, etc. and toasting bread.
			 only for model without broil rack	

USING THE CONTROLS

Thermostat dial (A)

Select the desired temperature, as follows:

- To defrost (*only on some models*) (see page 14): Thermostat dial in the “**0**” position.
- To keep food warm (see page 14): Thermostat dial in the “**60°C**” position.
- For convection oven cooking (*only on some models*) or traditional oven cooking (see page 14-15): Thermostat dial from “**60°C**” to “**220°C**”.
- For all types of grilling (see page 16): Thermostat dial in the “**▼▼▼**” position.

Timer dial (B)

- To program the cooking time: Turn the dial clockwise to the desired time (max. 120 minutes); when the set time has elapsed, an audible signal (*only on some models*) will be emitted and the oven will automatically switch off.
- To switch the oven off: Turn the dial to the “**0**” position

To set times less than 20 minutes, first turn the dial all the way round, then back anti-clockwise to the desired time.

Function selector dial (D)

This dial is used to select the cooking functions available, that is:

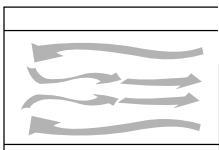

-  DEFROSTING
(*only on some models*)
(ventilation only)

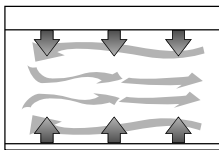

-  CONVECTION OVEN COOKING
(*only on some models*)
(top heating element, bottom heating element and ventilation on)

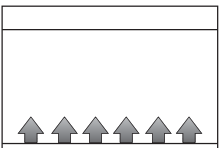

-  DELICATE COOKING
(bottom heating element on)

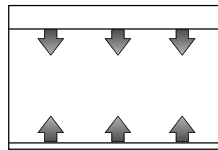

-  TRADITIONAL OVEN COOKING, KEEPING FOOD WARM
(top heating element and bottom heating element on)

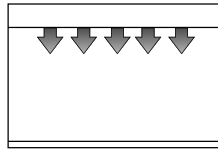

-  GRILLING
(top heating element on at maximum power)

Indicator light (C)

The light on means that the oven is on.

Inside light (N) (*only on some models*)

When the oven is on, the light inside the oven is always on. To replace the bulb, proceed as follows: unplug the appliance from the power socket, unscrew the glass cover and replace the burnt-out bulb with a new one of the same type (resistant to high temperatures) and then replace the glass cover.

USING THE OVEN

General tips

- When cooking with the convection oven, traditional oven and grilling, always preheat the oven for 5 minutes to the set temperature, so as to achieve best results.
- The cooking times depend on the quality of the products, on the temperature of the food and on personal tastes. The times indicated in the table are purely indicative and subject to variation, and do not include the time required to preheat the oven.
- To cook frozen foods refer to the recommended times on the product packaging.

Wire rack insertion/extraction system (*only on some models*)

If the oven is equipped with a wire rack insertion/extraction lever, follow these simple instructions:

- **To insert the wire rack:** push the wire rack towards the back of the oven past the rubber pad on the left of the oven until it clicks into place. When the door is closed, the wire rack automatically moves into position.
- **To remove the wire rack:** open the door. The wire rack is automatically ejected by a couple of centimeters. Grip it with an oven mitt and pull towards you.

Defrosting (only on some models)

For full defrosting in a short time, proceed as follows:

- Turn the function selector dial (D) to the  position.
- Turn the thermostat dial (A) to the “*” position.
- Turn the Timer dial (B) to the desired time.
- Place the flat wire rack (G) in the lower guide and rest the food to be defrosted on a tray on the wire rack, then close the door.

Example of defrosting: 1 kg of meat, 80-90 minutes without turning it over.

Delicate cooking

Ideal for pastry and cakes with icing. Good results are also achieved when completing the cooking of the bottom of the foods or for cooking that requires heat at the bottom.

- Place the wire rack (with a pan on it) in the lower guide, as shown in the summary table figure on page 12.
- Turn the function selector dial (D) to the  position.
- Select the required temperature using the thermostat dial (A).
- Turn the Timer dial (B) to the desired time. At the end of the set time, an audible signal will be emitted; if cooking is complete before the end of the set time, turn the Timer dial (B) manually to the “0” position.

Keeping food warm

- Turn the thermostat dial (A) to the “60°C” position.
- Turn the function selector dial (D) to the  position.
- Turn the Timer dial (B) to the desired time.
- Place the flat wire rack (G) in the lower guide and rest the dish with the food on the rack.

It is recommended not to leave the foods in the oven for too long, as these may dry out.

Convection oven cooking (only on some models)

This function is ideal for lasagna, dishes, all types of meat dishes (apart from small poultry), roast potatoes, cakes in general and bread.

It is also suitable for cooking different foods on two levels at the same time. Proceed as follows:

- Place the flat wire rack (G) in the position shown in the summary table.
- Turn the function selector dial (D) to the  position.
- Select the required temperature by turning the thermostat dial (A).
- Turn the Timer dial (B) to the desired time.
- After having pre-heated the oven for 5 minutes, place the food to be cooked inside.

The cooking times depend on the quality of the products, on the temperature of the food and on personal tastes. The times indicated in the table are purely indicative and subject to variation, and do not include the time required to preheat the oven.

Program	Thermostat knob	Times	wire rack position	Comments and tips
Macaroni “au gratin” 1 Kg.	220°	20 min.	lower	Turn the baking pan halfway through cooking
Chicken 1 kg.	200°	70-80 min.	“	Use the dripping pan, turn after around 38 min.
Meatballs 650 g	180°	55 min.	“	Use the dripping pan, turn after around 30 min.
Roast potatoes 500 g	200°	50 min.	“	Use the dripping pan, mix twice.
Strudel 1 kg	180°	40 min.	“	Use the dripping pan.
Walnut cakes 800 g	180°	35 min.	“	Use a cake dish.
Biscuits (shortbread) 100 g	180°	14 min.	“	Use the dripping pan.
Bread 500 g	200°	25 min.	“	Use the dripping pan greased with oil.

Traditional oven cooking

This function is ideal for all types of fish, pizzas, stuffed vegetables, cakes with whipped egg-whites and cakes that require long cooking times (over 60 min.). Proceed as follows:

- Place the wire rack in the position shown in the table.
- Turn the function selector dial (D) to the  position.

- Select the required temperature by turning the thermostat dial (A).
- Turn the Timer dial (B) to the desired time.
- After having pre-heated the oven for 5 minutes, place the food inside.

Program	Thermostat knob	Times	wire rack position	Comments and tips
Lasagna 1 kg.	220°	20 min.	lower	Use an ovenproof dish, turn after 10 min.
Pizza 500 g	220°	17 min.	"	Use the dripping pan.
Roast pork 900 g	200°	70 min.	"	Use the dripping pan, turn after around 35 min.
Quail (3)	220°	44 min.	"	Use the dripping pan, turn after 24 minutes.
Trout 500g	200°	35 min.	"	Use the dripping pan, turn after 16 minutes.
Stuffed calamari 450g	200°	30 min.	"	Use an ovenproof dish, turn halfway through cooking.
Tomatoes "au gratin" 550g	200°	40 min.	"	Use the dripping pan greased with oil and turn after 20 min.
Zucchini with tuna 750g	200°	40 min.	"	Use the dripping pan; add oil, the tomatoes and water; turn the dripping pan after 20 min.
Plum cakes 1 kg	180°	75 min.	"	Use a mold and turn halfway through cooking.
Meringues	120°	50 min.	"	Use the dripping pan greased with oil. Let them rest for at least 1 day before serving.
Jam tarts 700 g	180°	40 min	"	Use the dripping pan.

Grilling

- Place the flat wire rack (G) in the upper guide.
- Turn the function selector dial (D) to the  position.
- **If your oven features the broil rack (O):** place the food to be grilled on the broil rack (O) inserted on the drip pan (H), and place them together on the flat wire rack (G).

- **If your oven does not feature the broil rack (O):** place the food directly on the flat wire rack (G) (the drip pan (H) must be placed over the bottom heating element, to catch any fat that drips).
- Close the door.
- Turn the Timer dial (B) to the desired time.

Program	Thermostat dial	Times	wire rack position	Comments and tips
Pork chops (2)	▼▼▼	26 min.	upper	Turn after 14 minutes.
Frankfurters (3)	"	20 min.	"	Turn after 11 minutes.
Fresh hamburgers (2)	"	25 min.	"	Turn after 13 minutes.
Sausages (4)	"	26 min.	"	Turn after 14 minutes.
Kebabs 500g	"	26 min.	"	Turn after 8, 15 and 21 minutes.
Toasted bread (4 slices)	"	9 min.	"	Turn after 6 minutes.

Please Note: The drip pan does not need to be placed inside the oven for toasting bread.

Cooking on 2 levels at the same time with the convection oven (only on some models)

The convection oven function allows different foods to be cooked at the same time, placed on 2 levels.

The heat provided by the 2 heating elements is distributed inside the oven by the air, circulated by the fan.

In this way, the heat reaches every part of the oven **uniformly and quickly**; the air inside the oven is very dry, preventing the mixing of fragrances and flavours.

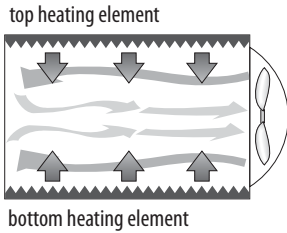

To cook two dishes at the same time, simply observe these simple general rules.

1. The cooking times for recipes cooked at the same time are higher than the times when cooked alone.
2. Around halfway through cooking, **exchange the position** of the 2 dripping pans, placing the top one on the lower wire rack and vice-versa, fig. 1.

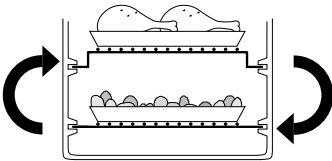

fig. 1

In addition, **turn** the drip pans **half-way** around, fig. 2.

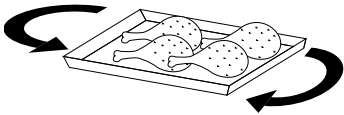

fig. 2

Note: The wire racks must be positioned as shown in the fig. 3 to the side.

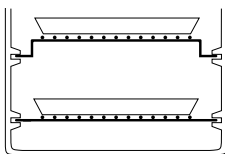

fig. 3

CLEANING AND MAINTENANCE

Frequent cleaning prevents the formation of smoke and bad odours during cooking. Do not let fat accumulate inside the appliance. Before any maintenance or cleaning operation, unplug the oven and wait for it to cool down. Clean the door, the inside walls and the enamel or painted surfaces of the oven with a soap and water solution; dry thoroughly, fig. 4. To clean the aluminium surfaces on the inside of the oven, never use products that corrode aluminium (detergents in spray cans) and never scrape the walls with sharp objects, fig. 5. To clean the outside surface always use a damp sponge. Avoid using abrasive products that may damage the paintwork. Make sure water or liquid soap does not seep into the slits on the top of the oven. **Never immerse the appliance in water; never wash it under a jet of water.** All the accessories are washed like normal dishes, either by hand or in the dishwasher.

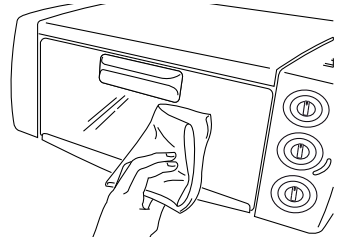

fig. 4

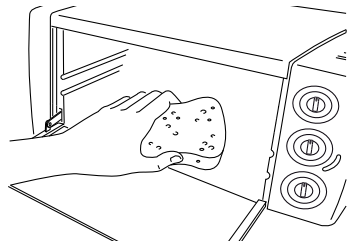

fig. 5

If the oven has a crumb tray:

Make sure the oven is completely cold before removing the crumb tray. Remove the tray from the bottom fig. 6; wash it by hand. If the dirt is hard to remove, rinse the tray in hot soapy water and if necessary rub it gently, without scratching it.

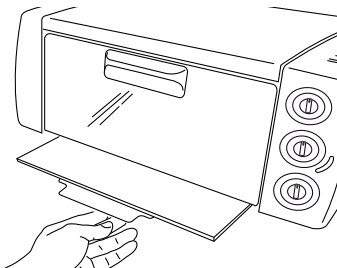

fig. 6

TECHNICAL DATA

Net weight 5 kg
Absorbed power 1400 W
Frequency 50/60 Hz
Voltage 220-240 V

Important information for correct disposal of the product in accordance with EC Directive 2002/96/EC.



At the end of its working life, the product must not be disposed of as urban waste. It must be taken to a special local authority differentiated waste collection centre or to a dealer providing this service. Disposing of a household appliance separately avoids possible negative consequences for the environment and health deriving from inappropriate disposal and enables the constituent materials to be recovered to obtain significant savings in energy and resources. As a reminder of the need to dispose of household appliances separately, the product is marked with a crossed-out wheeled dustbin.

FOR U.K. ONLY

Wiring instructions

This appliance must be earthed

Important: The wires in this lead are coloured in accordance with the following codes:

Green and yellow:	Earth
Blue:	Neutral
Brown:	Live

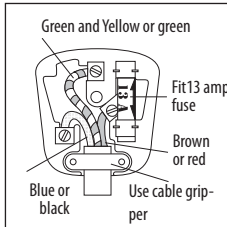

Connect the green/yellow wire to the terminal in the plug marked "E"

(or by the earth symbol) or coloured green or coloured green and yellow.

Connect the brown wire to the terminal in the plug marked "L" or coloured red.

Connect the blue wire to the terminal in the plug marked "N" or coloured black.

A 13 amp fuse should be fitted when the appliance is connected to a BS 1363 plug.

Seek professional advice if you are unsure of the correct procedure for the above.

About your factory fitted plug (supplied with certain models only)

The lead is already fitted with a plug incorporating a 13 amp fuse. If the plug does not fit your socket outlet, see next para-

graph. Should you need to replace the fuse in the plug supplied, a 13 amp approved BS 1362 fuse must be used. (refer to wiring instructions for use rating) If the plug supplied does not fit your socket outlet, it should be removed from the mains lead and disposed of safely. The flexible cord insulation should be stripped back as appropriate and a suitable alternative plug fitted. The replacement plug must be equipped with a 13 amp fuse.

Important: If the electrical cord of this appliance is damaged, it must only be replaced by an authorised Service Dealer. The safety of this appliance complies with the technical regulations and standards in force.

