

# KENWOOD

BL760 series  
BL770 series

instructions

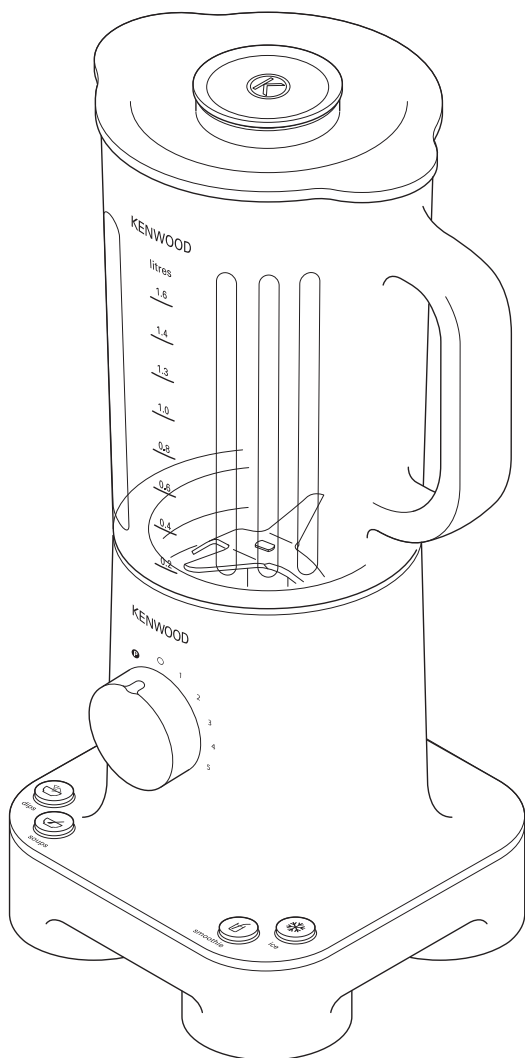

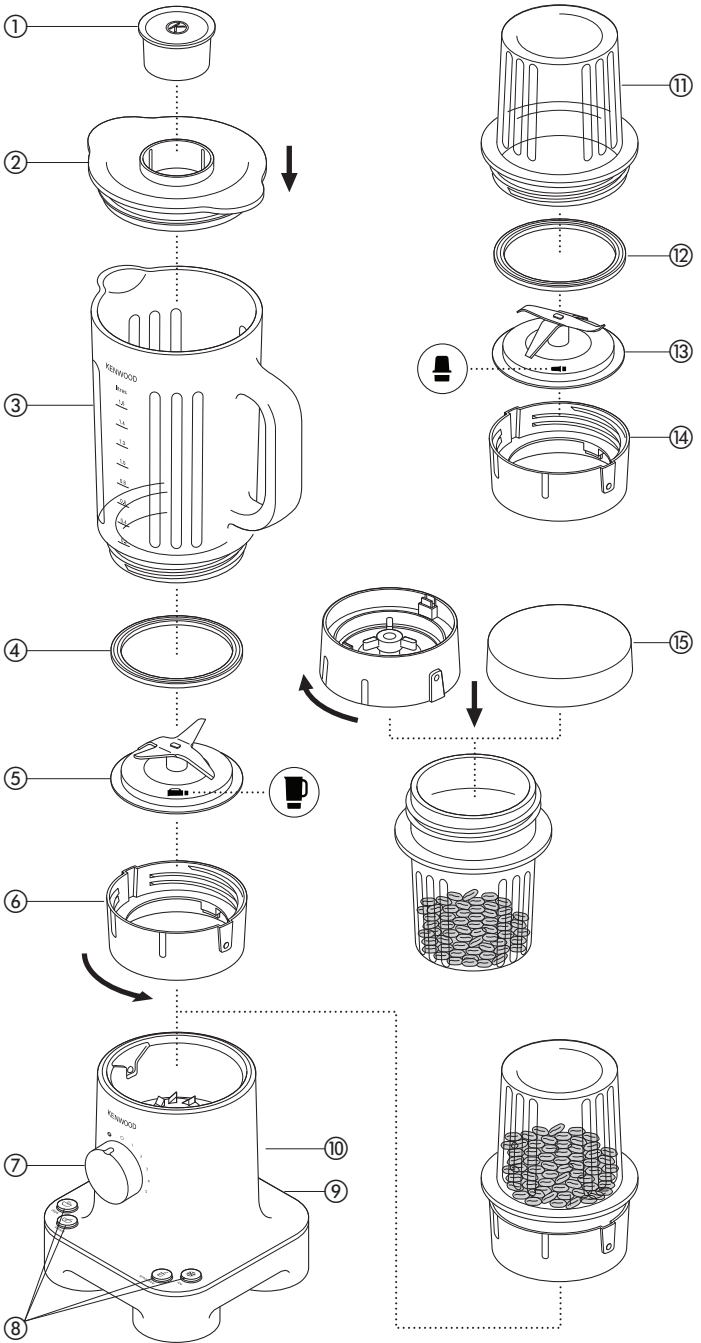

Use your blender for soups, drinks, pâtés, mayonnaise, breadcrumbs, biscuit crumbs, chopping nuts and crushing ice. Use your mill (if supplied) for milling herbs, nuts, coffee beans, spices and purées.

### **before using your Kenwood appliance**

- Read these instructions carefully and retain for future reference.
- Remove all packaging and any labels.
- Wash the parts: see 'care and cleaning'.

## safety

- Switch off and unplug:
  - before fitting or removing parts;
  - when not in use;
  - before cleaning.
- **Never fit the blade unit to the power unit without the blender goblet or mill jar fitted.**
- Always unplug the appliance before putting your hands or utensils in the goblet.
- Always take care when handling the blade assembly and avoid touching the cutting edge of the blades when cleaning.
- Only operate the blender with the lid in place.
- Only use the goblet with the blade assembly supplied.
- Never let the power unit, cord or plug get wet.
- Never use a damaged appliance. Get it checked or repaired: see 'service and customer care'.
- Never use an unauthorised attachment.
- **SCALD RISK:** Hot ingredients should be allowed to cool to room temperature before blending.
- Never leave the appliance unattended when it is operating.
- When removing the blender or mill from the power unit:
  - wait until the blades have completely stopped;
  - don't accidentally unscrew the goblet or mill jar from the blade assembly.

- Never run the blender empty.
- Never blend more than the maximum capacity stated in the recommended speed chart.
- To ensure long life of your blender and mill, do not run it for longer than 60 seconds.
- Smoothie recipes - never blend frozen ingredients that have formed a solid mass during freezing, break it up before adding to the goblet.
- Don't use the blender as a storage container. Keep it empty before and after use.
- Always use the blender on a secure, dry level surface.
- Never place this appliance on or near a hot gas or electric burner or where it could touch a heated appliance.
- Misuse of your blender can result in injury.
- This appliance is not intended for use by persons (including children) with reduced physical, sensory or mental capabilities, or lack of experience and knowledge, unless they have been given supervision or instruction concerning use of the appliance by a person responsible for their safety.
- Children should be supervised to ensure that they do not play with the appliance.
- Only use the appliance for its intended domestic use. Kenwood will not accept any liability if the appliance is subject to improper use, or failure to comply with these instructions.
- The maximum rating is based on the attachment that draws the greatest load. Other attachments may draw less power.

### **before plugging in**

- Make sure your electricity supply is the same as the one shown on the underside of the appliance.

### Important - UK only

- The wires in the cord are coloured as follows:  
Blue = Neutral  
Brown = Live.
- The appliance must be protected by a 13A approved (BS1362) fuse.

#### Note:

- For non-rewireable plugs the fuse cover MUST be refitted when replacing the fuse. If the fuse cover is lost then the plug must not be used until a replacement can be obtained. The correct fuse cover is identified by colour and a replacement may be obtained from your Kenwood Authorised Repairer (see Service).
- If a non-rewireable plug is cut off it must be DESTROYED IMMEDIATELY. An electric shock hazard may arise if an unwanted non-rewireable plug is inadvertently inserted into a 13A socket outlet.
- This appliance conforms to EC directive 2004/108/EC on Electromagnetic Compatibility and EC regulation no. 1935/2004 of 27/10/2004 on materials intended for contact with food.

## key

### blender

- ① filler cap
- ② lid
- ③ goblet
- ④ blender sealing ring
- ⑤ blender blade unit
- ⑥ base
- ⑦ speed + pulse control
- ⑧ pre-programmed buttons
- ⑨ power unit
- ⑩ cord storage

### mill (if supplied)

- ⑪ mill jar
- ⑫ mill sealing ring
- ⑬ mill blade unit
- ⑭ mill base
- ⑮ mill lid

## to use your blender





- 1 Fit the sealing ring ④ to the blender blade unit ⑤ marked  – ensuring the seal is located correctly in the grooved area.
- **Leaking will occur if the seal is damaged or incorrectly fitted.**
- 2 Clip the blade unit ⑤ into the base ⑥.
- 3 Screw the blade assembly onto the goblet – ensuring the blade assembly is fully tightened.
- 4 Put your ingredients into the goblet.  
**Never blend more than 1.6 litres or more than 1 litre for frothy liquids like milkshakes.**
- 5 Fit the filler cap to the lid.
- 6 Fit the lid by pushing down until secure.
- 7 Place the blender onto the power unit.
- **The appliance won't work if the blender is incorrectly fitted.**
- 8 Plug in and the 4 pre-program buttons will light up.
- 9 Choose one of the following options:
  - Select one of the 4 pre-programmed buttons (refer to the function selector chart). When the required program button is pressed the lights on the other 3 buttons will go out. The blender will switch off automatically at the end of the pre-set time. If you wish to stop before the pre-set time, press the selected program button again.
  - Select speed 1 (low) to 5 (High) by turning the speed control. At the end of blending return the speed control to "0" before removing the blender.
  - (P) Pulse – operates the motor in a start/stop action. The pulse will operate for as long as it is held in position.
- NOTE: The pre-program lights will flash under the following circumstances
- The power unit is plugged in but the goblet is not fitted to the power unit.

- The goblet is removed from the power unit without switching the speed control to “0”.
- The power unit will not operate until the control is turned to “0” and a speed is reselected.

### hints

- To blend dry ingredients - cut into pieces, remove the filler cap, then with the machine running, drop the pieces down one by one. Keep your hand over the opening. For best results empty regularly.

- When making mayonnaise, put all the ingredients, except the oil, into the blender. Remove the filler cap. Then, with the appliance running, add the oil slowly through the hole in the lid.
- Thick mixtures, e.g. pâtés and dips, may need scraping down. If the mixture is difficult to process, add more liquid.

<b>pre-program setting speed chart</b> <b>During operation of the pre-program settings a change in speed may be noted - this is normal</b>			
pre-program setting	usage	max qty	pre-set operating time
	Drinks and cocktails	1.6 litres	60 seconds
	Frothing milk and milkshakes	1 litre	
	Smoothie drinks Place the fresh fruit and liquid ingredients in first (includes yoghurt, milk and fruit juices). Then add ice or frozen ingredients (includes frozen fruit, ice or ice cream)	1 litre liquid	
	Stock based soups	1.6 litres	30 seconds
	Soups using milk	1 litre	
	<b>Hot ingredients should be allowed to cool to room temperature before blending.</b> <b>Note: Slow start when program selected.</b>		
	Dips, fruit and vegetable purées (add liquid if difficult to process).	200g	60 seconds
	Mayonnaise	1 egg 150 mls oil	
	Ice Crushing <b>Automatic pulsing action</b>	8 cubes 150g	30 seconds

## to use your mill (if supplied)

- 1 Put your ingredients into the jar. (Refer to the mill recommended usage chart).
- 2 Fit the sealing ring ⑫ into the mill blade unit marked  – ensuring the seal is located correctly in the grooved area.
  - **Ensure that the seal is fitted correctly.**
- 3 Then clip the blade unit ⑬ into the mill base ⑭.
- 4 Turn the mill blade assembly upside down. Lower it into the jar, blades down. Turn in a clockwise direction to lock.
- 5 Place the mill onto the power unit.
- 6 Select a speed or use the pulse control. (Refer to the mill recommended usage chart).

- 7 After milling, you can replace the blade assembly with the mill lid.

### hints

- For optimum performance when processing spices we recommend that you do not process more than 50g at a time in the mill.
- Whole spices retain their flavour for a much longer time than ground spices so it is best to grind a small quantity fresh at a time to retain the flavour.
- To release the maximum flavour and essential oils whole spices are best roasted prior to milling.
- Herbs are best chopped when clean and dry.

## mill recommended usage chart

Ingredients	Max Qty	Speed	Operating time
Nuts	50g	5	10 seconds
Coffee Beans	50g	5	30 seconds
Uncooked Meat Beef Steak - cut into 2½ cm cubes	100g	Pulse	5 seconds
Herbs	10g	5	5 seconds
Baby Food & Fruit Purees	100g		30 seconds
Spices - black peppercorns, cardamom seeds, cumin seeds, coriander seeds, fennel seeds and whole cloves	50g	5	30-60 seconds

## care and cleaning

- Always switch off, unplug and dismantle before cleaning.
- Empty the goblet before unscrewing it from the blade unit.
- **Don't immerse the blade unit in water.**
- The blender goblet and mill jar can be washed in your dishwasher.

### power unit

- Wipe with a damp cloth, then dry.
- Don't immerse the power unit in water.
- Store excess cord in the storage area at the back of the power unit ⑩.

### blade assembly

- 1 Unscrew the blender or mill base from the goblet. Then remove the blade unit by pushing up from underneath.
- **Care should be taken when removing the blade unit from the blender or mill base.**
- 2 Remove and wash the sealing ring.
- 3 Don't touch the sharp blades – brush them clean using hot soapy water, then rinse thoroughly under the tap. **Don't immerse the blade unit in water.**
- 4 Leave to dry upside down.

### other parts

Wash by hand, then dry.



## service and customer care

- If the cord is damaged it must, for safety reasons, be replaced by KENWOOD or an authorised KENWOOD repairer.

### UK

If you need help with:

- using your appliance or
- servicing, spare parts or repairs (in or out of guarantee)

☎ call Kenwood customer care on 023 9239 2333. **Have your model number (ie BL760 or BL770) and date code (4 digit code ie 9T03) ready.** They are on the underside of the power unit.

### ● spares and attachments

☎ call 0844 557 3653.

### ● other countries

Contact the shop where you bought your appliance.

- Designed and engineered by Kenwood in the UK.
- Made in China.



### **IMPORTANT INFORMATION FOR CORRECT DISPOSAL OF THE PRODUCT IN ACCORDANCE WITH EC DIRECTIVE 2002/96/EC.**

At the end of its working life, the product must not be disposed of as urban waste.

It must be taken to a special local authority differentiated waste collection centre or to a dealer providing this service.

Disposing of a household appliance separately avoids possible negative consequences for the environment and health deriving from inappropriate disposal and enables the constituent materials to be recovered to obtain significant savings in energy and resources. As a reminder of the need to dispose of household appliances separately, the product is marked with a crossed-out wheeled dustbin.

### **guarantee (uk only)**

If your blender goes wrong within one year from the date you bought it, we will repair it (or replace it if necessary) free of charge provided:

- you have not misused, neglected or damaged it;
- it has not been modified (unless by Kenwood);
- it is not second-hand;
- it has not been used commercially;
- you have not fitted a plug incorrectly; and
- **you supply your receipt to show when you bought it.**

This guarantee does not affect your statutory rights.



HEAD OFFICE: Kenwood Limited, 1-3 Kenwood Business Park, New Lane, Havant, Hampshire PO9 2NH

[kenwoodworld.com](http://kenwoodworld.com)

**KENWOOD**  
CREATE MORE